



## Gas Burner Controls

## LGA...

---

The LGA... are used for the startup and supervision of atmospheric gas burners of small to medium capacity (without fan) in intermittent operation.

The LGA... and this Data Sheet are intended for use by OEMs which integrate the gas burner controls in their products.

### Use

---

The flame is supervised with an ionization probe. Using the appropriate adapters, the LGA... can replace their predecessor types LFI7... and LFI5... in terms of function and size (refer to «Ordering»). LGA41.173A27 and LGA52.171B27 are suited for use with direct-fired air heaters.

## Warning notes

---



**To avoid injury to persons, damage to property and the environment, the following warning notes must be observed!**

**Do not open, interfere with or modify the unit.**

- All activities (mounting, installation and service work, etc.) must be performed by qualified staff
- Before making any wiring changes in the connection area, completely isolate the plant from mains supply (all-polar disconnection). Ensure that the plant cannot be inadvertently switched on again and that it is indeed dead. If not observed, there is a risk of electric shock hazard
- Ensure protection against electric shock hazard by providing appropriate protection for the burner control's connections terminals
- Each time work has been carried out (mounting, installation, service work, etc.), check to ensure that wiring is in an orderly state and make the safety checks as described in «Commissioning notes»
- Press the lockout reset button / operating button only manually (applying a force of no more than 60 N), without using any tools or pointed objects
- Fall or shock can adversely affect the safety functions. Such units must not be put into operation even if they do not exhibit any damage

## Mounting notes

---

Sitting the ionization probe

- Ensure that the relevant national safety regulations are complied with
- The ionization probe and ignition electrode must be positioned such that the ignition spark cannot arc over to the ionization probe
- The position and polarity of the ignition electrode can adversely affect the magnitude of the flame signal. Reversal of polarity of the ignition transformer's connections on the primary side usually solves the problem
- Since the burner bars form the earthed counter-electrode, the burner must be adjusted such that the flame is hot and stable and in firm contact with the burner bars. With pulsating flames or yellow-burning flames resulting from lack of air, a very low or even no ionization current is generated so that the burner control will initiate lockout

## Installation notes

---

- Always run the high-voltage ignition cables separate from the unit and other cables while observing the greatest possible distances
- Make absolutely certain that life and neutral conductors are correctly connected to terminals 1 and 2 of the burner control; otherwise, no flame signal will be generated
- Install switches, fuses, earthing, etc., in compliance with local regulations
- The connection diagrams shown apply to burner controls with earthed neutral conductor. In the case of ionization current supervision in networks with nonearthed neutral conductor, terminal 2 must be connected to the earth conductor via an RC unit (part no. ARC 4 668 9066 0). In that case, it must be made certain that the relevant national safety regulations are complied with (e.g. electric shock hazard protection), since AC 230 V / 50 Hz mains voltage results in a leakage current of 2.7 mA
- Make certain that the maximum permissible current rating of the connection terminals will not be exceeded
- Do not feed external mains voltage to the control outputs of the unit. When testing the devices controlled by the burner control (fuel valves, etc.), the LGA... must not be connected
- To isolate the burner control from the mains supply, use an all-polar switch with a contact gap of at least 3 mm
- Secure the earthing lug in the terminal base with a metric screw and a lockwasher or similar
- Switches, fuses, earthing, etc., must be in compliance with local regulations; primary fuse max. 10 A (fast)
- Connect the gas pressure switch and other monitoring devices - whose contacts must be closed from startup to controlled shutdown - in series with «R» and «W»

### Only with LGA41...

- If the fully closed position of the main valve «BV2» shall be checked on burner startup, the closed position contact must be included in the loop between terminals 9 and 3. In addition, the connecting links between terminals 9 and 11 and 8 and 3 must be fitted
- During the startup sequence, terminal 6 carries voltage and must not be used as an auxiliary terminal
- The auxiliary contact of a gas valve for checking the fully closed position must be included in the loop between terminals 9 and 3

### Only with LGA52... / LGA63...

- During the startup sequence, terminals 9 and 6 carry voltage and must not be used as auxiliary terminals
- Connect the load controller of 2-stage burners to terminal 5 in series with «BV2»

## Electrical connection of ionization probe

---

It is important to achieve practically disturbance- and loss-free signal transmission:

- Never run the detector cable together with other cables
  - Line capacitance reduces the magnitude of the flame signal
  - Use a separate cable
- Observe the permissible length of the detector cable (refer to «Technical data»)
- The ionization probe is not protected against electric shock hazard
- Locate the ignition electrode and the ionization probe such that the ignition spark cannot arc over to the ionization probe (risk of electrical overloads) and that it cannot adversely affect the supervision of ionization
- Insulation resistance
  - Must be a minimum of 50 MΩ between ionization probe and ground even after a large number of operating hours
  - Prerequisite for this is not only high quality heat-resistant insulation of the electrode cable, but also of the ionization probe itself (ceramic holder!)
  - Soiled detector holders reduce the insulation resistance, thus supporting creepage currents
- The burner (as the counter-electrode) must be correctly earthed, or else no ionization current will flow



Earthing the boiler alone does not suffice!

## Commissioning notes

---

- When commissioning the plant or when doing maintenance work, make the following safety checks:

	<b>Safety check to be carried out</b>	<b>Anticipated response</b>
a)	Burner startup with no flame signal; for that purpose, open the connection between burner control and ionization probe prior to burner startup and maintain that status	Lockout at the end of «TSA»
b)	Burner operation with simulated loss of flame during operation; for that purpose, open the connection between burner control and ionization probe during burner operation and maintain that status	Restart, followed by lockout at the end of «TSA»
c)	No air pressure signal during «t1» (only with LGA52... / LGA63... with auxiliary fan)	No startup
d)	Air pressure failure during operation (only with LGA52... / LGA63... with auxiliary fan)	Shutdown

## Standards and certificates



Conformity to EEC directives  
 - Electromagnetic compatibility EMC (immunity)  
 - Directives for gas-fired appliances  
 - Low-voltage directive

2004/108/EC  
 90/396/EEC  
 2006/95/EC



ISO 9001: 2000  
 Cert. 00739



ISO 14001: 2004  
 Cert. 38233

			
LGA41.153A27	---	---	X
LGA41.173A27	X	X	---
LGA52.150B17	X	---	---
LGA52.150B27	X	---	---
LGA52.171B27	X	---	---
LGA63.191A27	X	---	---

- Identification code to EN 298
  - Single-stage **A M C L X N**
  - 2-stage **A T C L X N**

## Life cycle

Burner controls has a designed lifetime\* of 250,000 burner startup cycles which, under normal operating conditions in heating mode, correspond to approx. 10 years of usage (starting from the production date given on the type field). This lifetime is based on the endurance tests specified in standard EN298 and the table containing the relevant test documentation as published by the European Association of Component Manufacturers (Afecor) ([www.afecor.org](http://www.afecor.org)).

The designed lifetime is based on use of the burner controls according to the manufacturer's Data Sheet. After reaching the designed lifetime in terms of the number of burner startup cycles, or the respective time of usage, the burner control is to be replaced by authorized personnel.

\* The designed lifetime is not the warranty time specified in the Terms of Delivery

## Disposal notes



The unit contains electrical and electronic components and must not be disposed of together with household waste. Local and currently valid legislation must be observed.

## Mechanical design

LGA...	<p>The gas burner controls are of plug-in design, suitable for installation in any position on burners, in control cabinets or on control panels.</p> <p>The housing is made of impact-proof, heat-resistant plastic and accommodates:</p> <ul style="list-style-type: none"> <li>- The thermal sequencing device (ambient temperature-compensated) acting on a multiple snap action switching system,</li> <li>- The flame signal amplifier with the flame relay, and</li> <li>- The lockout warning lamp and lockout reset button (splash-proof)</li> </ul>
Undervoltage detection	<p>In the event mains voltage drops below about AC 165 V, an electronic circuit ensures that the gas burner control will prevent burner startup or – without releasing fuel – lock-out will be initiated.</p>
Only with LGA63.191A27	<ul style="list-style-type: none"> <li>• Undervoltage threshold: AC 178 V ±10 V</li> <li>• «TSA»: Smaller tolerance band</li> <li>• Flame signal amplifier: Higher sensitivity, for typical applications with pilot flames</li> </ul>

## Type summary

The type references given in the table refer to gas burner controls with no base and no accessories.

Burner with undervoltage detection	AC 230 V	---	---	---	---	<b>LGA63.191A27</b>
	AC 220...240 V	---	<b>LGA41.173A27</b>	<b>LGA52.150B27</b>	<b>LGA52.171B27</b>	---
	AC 100...110 V	---	---	<b>LGA52.150B17</b>	---	---
Burner without undervoltage detection	AC 220...240 V	<b>LGA41.153A27</b>	---	---	---	---
	AC 100...110 V	---	---	---	---	---
Connection facility for auxiliary fan <sup>1)</sup>		---	---	x	x	x
Connection facility for air pressure switch		---	---	x	x	x
Control outputs for gas valves		2	2	2	2	2
Reversed polarity protection		x	x	x	x	x

1) Auxiliary fan not monitored to EN 298

## Ordering

**Gas burner control** (without plug-in base) refer to «Type summary»

**Connection accessories for small burner controls** refer to Data Sheet N7201

- Plug-in base AGK11...
- Cable holders AGK65..., AGK66, AGK67...
- Cable strain relief elements for AGK67...

**Connection accessories for small burner controls** refer to Data Sheet N7203

- Plug-in base AGK13...
- Plug-in housing AGK56
- Cover AGK68

**Ionization probe** supplied by thirds



**Pedestal** **AGK21**

- For increasing the height of the LGA... to that of the LFI1... or LFI5...



**RC unit** (for the supervision of ionization currents in networks with nonearthened neutral conductor) **ARC 4 668 9066 0**

## Technical data

General unit data	Mains voltage	AC 220 V –15 %...AC 240 V +10 % AC 100 V –15 %...AC 110 V +10 %
	- Only with LGA63...	AC 230 ±10 %
	Mains frequency	50...60 Hz ±6 %
	Power consumption	3 VA
	Input current at terminal 1	Max. 5 A
	Perm. electrical rating	
	- Terminal 4	Max. 4 A
	- Terminal 5	Max. 1 A
	- Terminal 6	Max. 2 A
	- Terminal 7	Max. 2 A
	- Terminal 8	Max. 4 A
	- Terminal 9	Max. 0,1 A
	- Terminal 10	Max. 1 A
Degree of protection	IP40 (when integrated)	
Perm. mounting position	Optional	
Weight	Approx. 180 g	

Environmental conditions	<b>Storage</b>	DIN EN 60721-3-1
	Climatic conditions	Class 1K3
	Mechanical conditions	Class 1M2
	Temperature range	-20...+60 °C
	Humidity	<95 % r.h.
	<b>Transport</b>	DIN EN 60721-3-2
	Climatic conditions	Class 2K2
	Mechanical conditions	Class 2M2
	Temperature range	-50...+60 °C
	Humidity	<95 % r.h.
	<b>Operation</b>	DIN EN 60721-3-3
	Climatic conditions	Class 3K5
	Mechanical conditions	Class 3M2
	Temperature range	0...+60 °C For LGA41.173A27 and LGA52.171B27: -20...+60 °C
	Humidity	<95 % r.h.



**Condensation, formation of ice and ingress of water are not permitted!**

Flame supervision with ionization probe	Voltage between ionization probe and ground	Mains voltage
	Required detector current	Min. 5 µA
	Possible detector current	Max. 100 µA
	Length of detector cable	Max. 20 m (separate cable)
	Required insulation resistance between ionization probe with its cable and ground	Min. 50 MΩ

## Function

Control sequence (Times in seconds) <sup>1)</sup>

	AC 220...240 V	LGA41.153A27	LGA41.173A27	LGA52.150B27	LGA52.171B27	LGA63.191A27
	AC 100...110 V	---	---	LGA52.150B17	---	---
t1	Prepurge time	---	---	Approx. 13	Approx. 13	Approx. 13
t3	Preignition time	15	15	---	---	---
t3'	Preignition time from start of «TSA»	---	---	Max. 5	4.5...7.5	Max. 10
TSA	Ignition safety time	5	10	5	4.5...7.5	10
TSAmax.	Max. ignition safety time	10	20	10	20	20
t3n	Postignition time	Max. 2	Max. 2	---	---	---
t4	Interval «BV1 – BV2»	Approx. 18	Approx. 13	Approx. 18	Approx. 13	Approx. 23

<sup>1)</sup> All times specified apply to AC 220 V and AC 110 V respectively  
For AC 240 V operations, above times are to be multiplied by 0.7

Control sequence in the event of fault

Fault	Response of LGA41...	Response of LGA52... / LGA63...
Erroneous flame signal during «t1» or «t3» (extraneous light)	Lockout <sup>2)</sup> prior to the release of gas	Lockout <sup>2)</sup> prior to ignition and the release of gas
No flame on completion of «TSA»	Lockout <sup>2)</sup>	Lockout <sup>2)</sup>
Loss of flame during operation	Repetition	Repetition
No air pressure signal during «t1»	---	No start
Air pressure failure during operation	---	Shutdown

<sup>2)</sup> After lockout, the burner control can be reset after about 60...90 seconds

Flame supervision with ionization probe

The conductivity and rectifying effect of hot flame gases are used for flame supervision. For that purpose, AC voltage is applied to the ionization probe which projects into the flame. The current that flows in the presence of a flame (ionization current) generates the flame signal which is then fed to the input of the flame signal amplifier. The amplifier is designed such that it only responds to the DC current component of the flame signal, thus ensuring that a short-circuit between ionization probe and ground cannot simulate a flame signal (since in that case, AC current would flow).



## Function (cont'd)

Internal diagram  
LGA41...

When the switch-on command is given, power is supplied to the ignition transformer and the heating coil of the bimetal sequencing device. The bimetal bends and pushes contact set «c, d, e» towards «f». On completion of the preignition time, the system tilts so that «e - f» closes and «f - g» opens, «BV1» receives voltage. Contacts «c - d» still remain closed («c» resting on «d»). On flame establishment, the flame relay is energized, latching mechanically «e - f» in the position now assumed. The relay also closes contact «f» and, at the same time, opens «c - d», so that the ignition transformer and the bimetal heating element will be switched off. Then, «d» slowly returns to its starting position, also catching «g». When tilting back, «g - f» closes, so that the main valve «BV2» will be energized.

If no flame signal is generated, the flame relay does not open «c - d», so that the bimetal will continue to be heated. The bimetal thus continues to bend until – tilting – it actuates contact «tz2»: → Lockout.

In the event of an erroneous premature flame signal, the flame relay – by means of its latch – prevents «e - f» from making, which means no release of fuel. «TZ», however, still receives power so that the bimetal continues to bend until, eventually; lockout is initiated by «tz2».

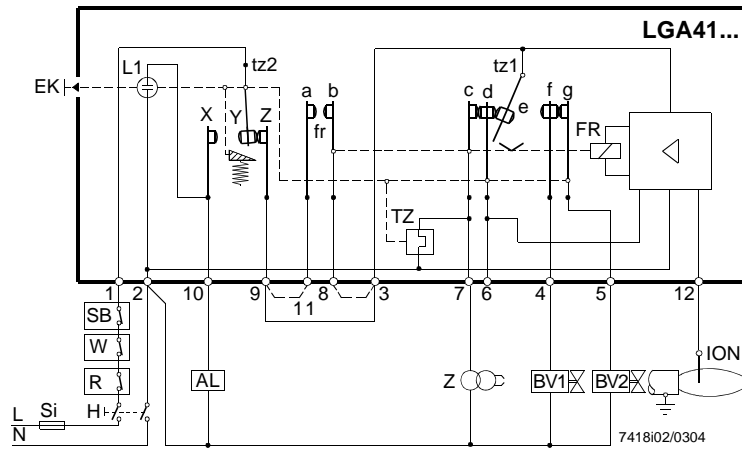

## Legend

AL	Fault status signal	R	Thermostat or pressurestat
BV...	Fuel valve	SB	Safety limit thermostat
EK	Lockout reset button	Si	External primary fuse
ION	Ionization probe	TZ	Electro-thermal timer (bimetal system) with contacts «tz»
FR	Flame relay	W	Limit thermostat / pressure switch
L1	Built-in lockout warning lamp	Z	Ignition transformer
H	Main switch		

## Function (cont'd)

Internal diagram  
LGA52... / LGA63...

When the switch-on command is given, the auxiliary fan starts to run. When the air pressure switch closes its contact, the heating coil of the bimetal sequencing device is energized and the bimetal pushes contact set «c, d, e» towards «f» (thereby opening «f - g»). On completion of the prepurge time, «e - f» is closed so that both fuel valve «BV1» and the ignition transformer receive voltage: The safety time starts. On flame establishment, the flame relay latches mechanically «e - f», pushes «c» back at the same time and opens «fr». The ignition transformer is thus switched off and the heating coil deenergized, so that «d» can revert to its starting position. When tilting back, «g - f» closes so that the main valve «BV2» receives voltage.

If no flame signal is generated, the flame relay does not open «c - d», so that the bimetal will continue to be heated. The bimetal thus continues to bend until – tilting – it actuates contact «tz2»: → Lockout

In the event of an erroneous premature flame signal, the flame relay – by means of its latch – prevents «e - f» from making, which means no release of fuel. «TZ», however, still receives power so that the bimetal continues to bend until, eventually; lockout is initiated by «tz2».

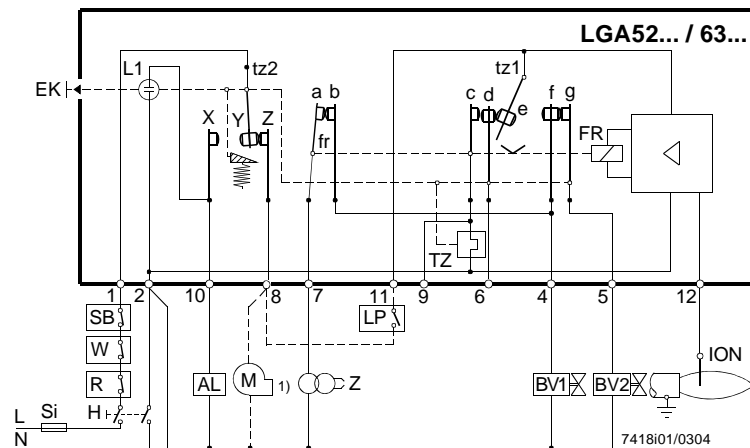

## Legend

AL	Fault status signal	H	Main switch
BV...	Fuel valve	M	Auxiliary fan
EK	Lockout reset button	R	Thermostat or pressurestat
ION	Ionization probe	SB	Safety limit thermostat
FR	Flame relay	Si	External primary fuse
L1	Built-in lockout warning lamp	TZ	Electro-thermal timer (bimetal system) with contacts «tz»
LP	Air pressure switch	W	Limit thermostat / pressure switch
1)	Not monitored to EN 298	Z	Ignition transformer

### Connection diagram

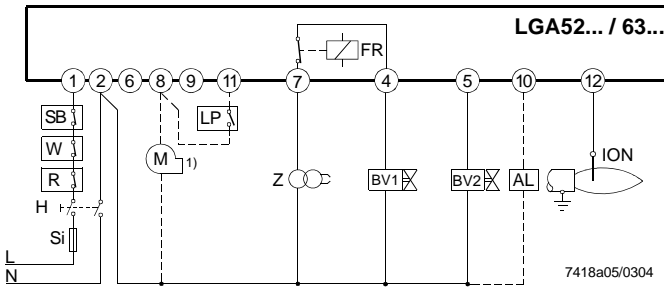
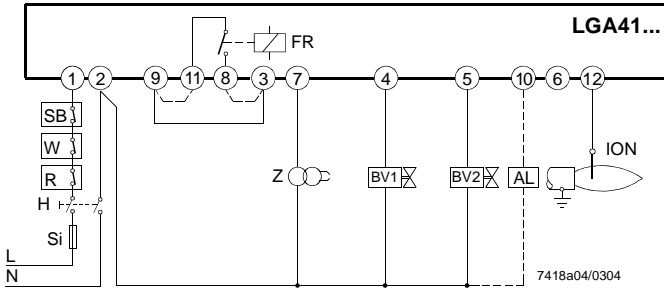

### Control sequence

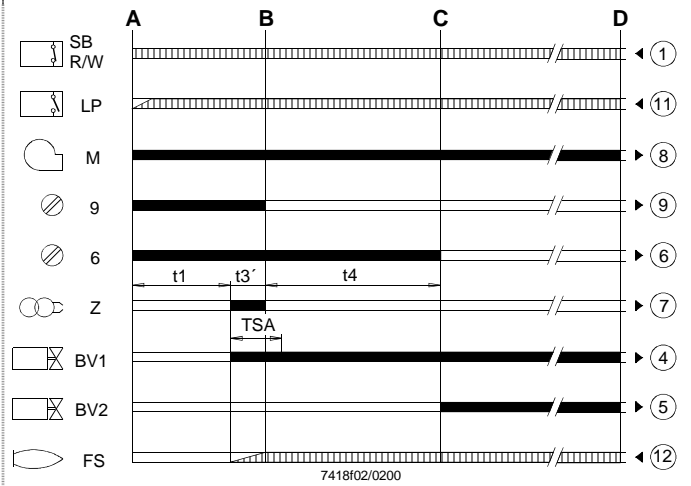
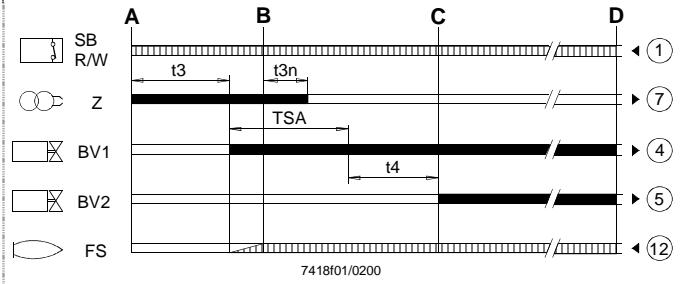

### Legend

- AL Fault status signal
- BV... Fuel valve
- ION Ionization probe
- FR Flame relay
- FS Flame signal
- LP Air pressure switch
- H Main switch

- Required input signals
- Burner control's output signals

- A Commencement of startup sequence
- B Time of flame establishment
- t1 Prepurge
- t3 Preignition time
- t3' Preignition time from the start of «TSA»

- M Auxiliary fan
- R Thermostat or pressurestat
- SB Safety limit thermostat
- Si External primary fuse
- W Limit thermostat / pressure switch
- Z Ignition transformer
- 1) Not monitored to EN 298
- C Operating position
- D Controlled shutdown by «R»
- t3n Postignition
- t4 Interval «BV1 – BV2»
- TSA Ignition safety time

## Dimensions

Dimensions in mm

LGA...



Plug-in base AGK11... / AGK13...

