

Double solenoid valve
Nominal width
Rp 2 (DN 50)
DN 65 - DN 125

DUNGS®
Combustion Controls

DMV/12
DMV-D/12
DMV-DLE/12

7.37

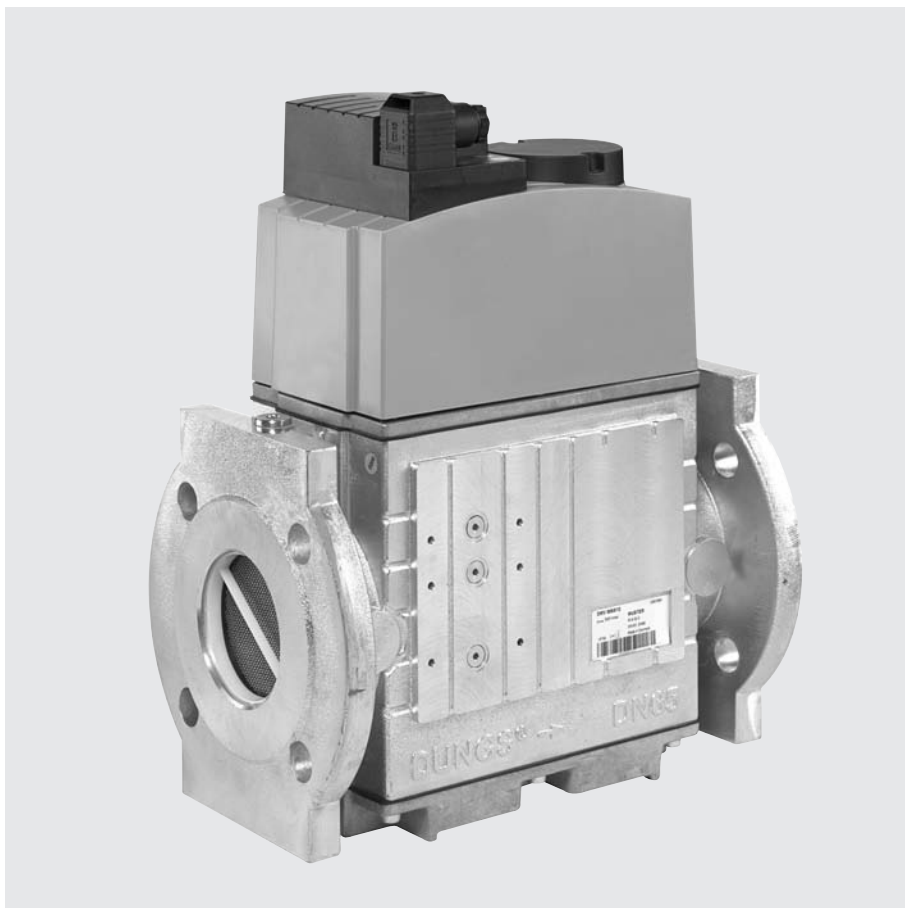

Technical Description

The DUNGS double solenoid valve DMV consists of two solenoid valves in one compact unit:

- Automatic shut-off valves as per DIN EN 161 Class A Group 2.
- Two A-valves in one housing
- Double disc valves
- High flow rates
- Max. operating overpressure 0.5 mbar (50 kPa)
- Fast-closing
- Fast-opening (DMV-D) or slow-opening (DMV-DLE) with adjustable fast stroke for start gas rate
- Adjustable main load (DMV-D, DMV-DLE)
- DC solenoid
- Closed position signal contact can be mounted
- Small dimensions, low weight

Application

Double solenoid valves are used at places where earlier two single valves were assembled. A large variety of regulation functions can be carried out by combining these valves with DUNGS gas pressure regulation devices and additional components. It does not contain any non-ferrous metals, suitable for gases of up to max. 0.1 vol.% H₂S, dry. Suitable for gases of families 1, 2, 3 and other neutral gaseous media.

Approvals

EU type test approval as per EU Gas Appliance Directive:
DMV-...D Rp 2 (DN 50) CE-0085 BO 0236
DMV-...DN 65-125 CE-0085 BO 0236
EU type test approval as per EU Pressure Equipment Directive:
DMV-...DN 65-125 CE0036
Approvals in other important gas-consuming countries.

Technical Data

Nominal width	DN 65	80	100	125	
Flanges	Connection flanges as per DIN 2501 part 1 for welding neck flanges as per DIN 2633 (PN16) DN 65 - DN 125, EN 1097-1 Length as per DIN 3202 part 1, series F1 for DN 65 - DN 125				
Nominal diameters	DMV 525/12				
Flange with pipe thread as per ISO 7-1	Rp 2 and their combinations				
Max. operating pressure	500 mbar (50 kPa)				
Solenoid valve V1	automatic shut-off valve as per EN 161: Class A, Group 2				
Solenoid valve V2	automatic shut-off valve as per EN 161: Class A, Group 2				
Closing time	< 1 s				
Opening time	DMV/12 + DMV-D/12: < 1 s DMV-DLE/12: approx. 20 s at room temperature + 20 °C and without fast stroke				
Fast stroke	adjustable (DMV-DLE/12)				
Main load restrictor	adjustable (DMV-D/12, DMV-DLE/12)				
Material used for gas-conveying parts	Housing:	aluminium, steel, no non-ferrous heavy metals			
	Seals at the valve seat:	NBR-based, suitable for gases as per G260/I			
Ambient temperature	-15 °C to +60 °C				
Installation position	Solenoid in upright vertical to horizontal position				
Dirt trap device	Filter integrated We recommend mounting an upstream gas filter to protect the entire gas train. See data sheet gas filter 11.02.				
Measuring gas connection	G 1/4 DIN ISO 228, in the centre before V1 and after V2 G 1/8 DIN ISO 228, on both sides before V1, between V1 and V2, after V2				
Ignition gas connection	Ignition gas flange G 3/4, DIN ISO 228 possible on both sides between V1 and V2				
Voltage / frequency	~(AC) 50 - 60 Hz 230 V -15 % + 10 %, other voltages on request. Standard voltages: ~(AC) 110 V - 120 V, =(DC) 24 V - 28 V				
Power / current draw at~(AC) 230 V, + 20 °C all indications are effective values	Type	Starting power approx. [W]	Holding power approx. [W]	Break-away starting current [A]	Holding current [A]
	DMV 525/12	2 x 65	2 x 16	2 x 0.32	2 x 0.11
	DMV-... 5065/12	2 x 95	2 x 20	2 x 0.54	2 x 0.20
	DMV-... 5080/12	2 x 125	2 x 25	2 x 0.54	2 x 0.20
	DMV-... 5100/12	2 x 125	2 x 25	2 x 0.54	2 x 0.20
	DMV-... 5125/12	2 x 130	2 x 25	2 x 0.56	2 x 0.20
Degree of protection / switch-on duration	IP 54 / 100 % duty				
Electrical connection	Plug-in connection as per DIN EN 175301-803				
Radio interference suppression	Interference level N				
Closed position signal contact	Type K01/1 (DIN tested) can be mounted at V1 and V2				

Dimensions for DMV-...-...

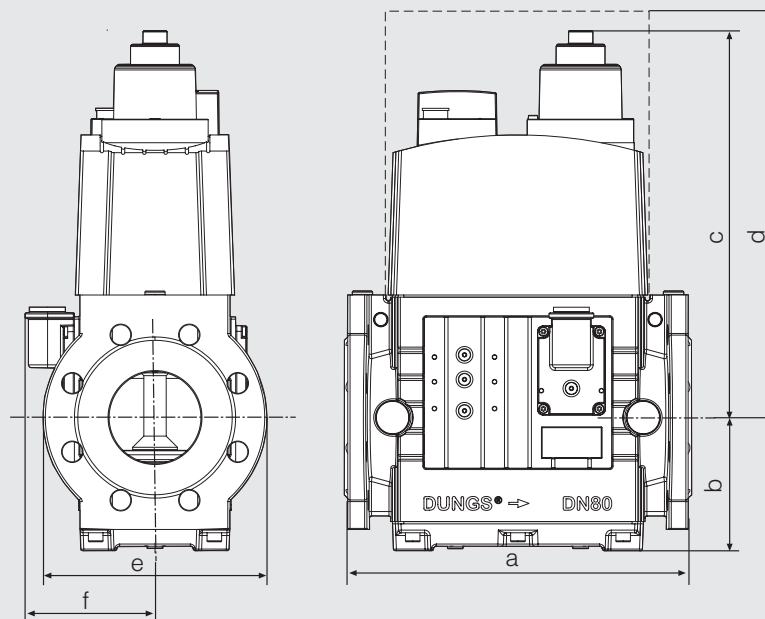
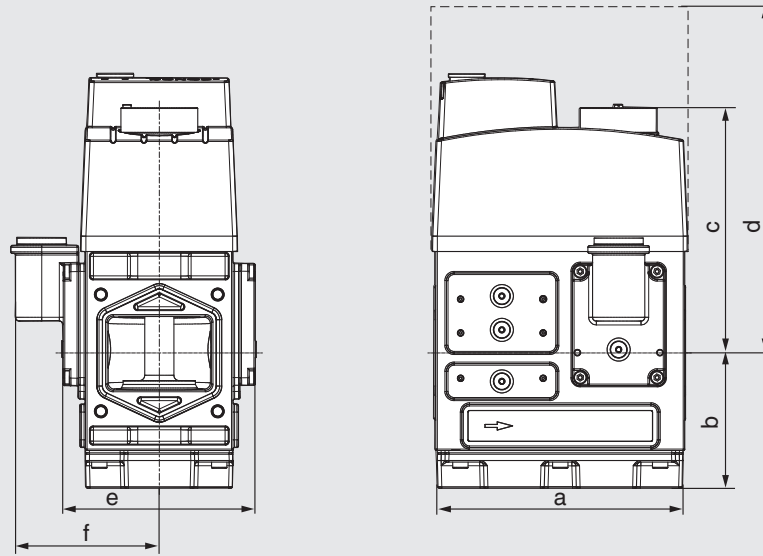

Type	Ordering no.	Connection DN	P _{max.} [W] ~-(AC) 230 V	Opening time	Dimensions in [mm]						Solenoid No.	Switching operations/h ¹⁾	Weight [kg]
					a	b	c	d	e	f			
DMV 525/12	on request	Rp 2 (DN 50)	130	< 1 s	162	88	179	275	125	97	1411/2P	60	7.0
DMV 5065/12	243 099	DN 65	190	< 1 s	290	104	246	365	185	110	1511/2P	60	16.2
DMV-D 5065/12	243 100	DN 65	190	< 1 s	290	104	246	365	185	110	1511/2P	60	16.2
DMV-DLE 5065/12	245 719	DN 65	190	< 20 s	290	104	265	365	185	110	1511/2PL	20	16.5
DMV 5080/12	244 427	DN 80	250	< 1 s	310	119	292	450	200	116	1611/2P	60	23.0
DMV-D 5080/12	244 294	DN 80	250	< 1 s	310	119	292	450	200	116	1611/2P	60	23.0
DMV-DLE 5080/12	245 686	DN 80	250	< 20 s	310	119	347	450	200	116	1611/2PL	20	23.3
DMV 5100/12	244 300	DN 100	250	< 1 s	350	142	329	500	220	125	1711/2P	60	29.0
DMV-D 5100/12	244 299	DN 100	250	< 1 s	350	142	329	500	220	125	1711/2P	60	29.0
DMV-DLE 5100/12	245 687	DN 100	250	< 20 s	350	142	390	500	220	125	1711/2PL	20	29.3
DMV-D 5125/12	246 383	DN 125	260	< 1 s	400	128	415	635	250	140	1811/2P	60	53.0

¹⁾ Number of switching operations for DMV-...-... also depends on the opening time



Note: Plug-in connection and system accessories must be

3 ... 6 ordered separately.

DMV/12	Two single stage solenoid valves, de-energised in absence of current, fast-opening, fast-closing.
DMV-D/12	Two single stage solenoid valves, de-energised in absence of current, fast-opening, fast-closing. Manual limitation of gas flow is possible with main load adjustment (D) at valve 1 (V1).
DMV-DLE/12	Two single stage solenoid valves, de-energised in absence of current, slow-opening (L), fast-closing. Adjustment of opening time (E) with fast stroke range at valve 2 (V2). Manual limitation of gas flow is possible with main load adjustment (D) at valve 1 (V1).

Variants Double solenoid valve DMV-.../12 single stage operating mode	DMV/12 Rp 2 (DN 50)	DMV/12 DN 65 - DN 125
DMV	◆	◆
DMV-D	--	◆
DMV-DLE	--	◆
Filter	◆	◆
Gas pressure switch can be mounted:		
on the flange	◆	(◆)
after the filter, before V1	◆	◆
between V1 and V2	◆	◆
after valve 2	◆	◆
valve V1, double seat	◆	◆
valve V2, double seat	◆	◆
Valves open separately	◆	◆
Ignition gas flange G 3/4	◆	◆

◆ = standard
 (◆) = on request
 -- = not possible

Modular system double solenoid valve

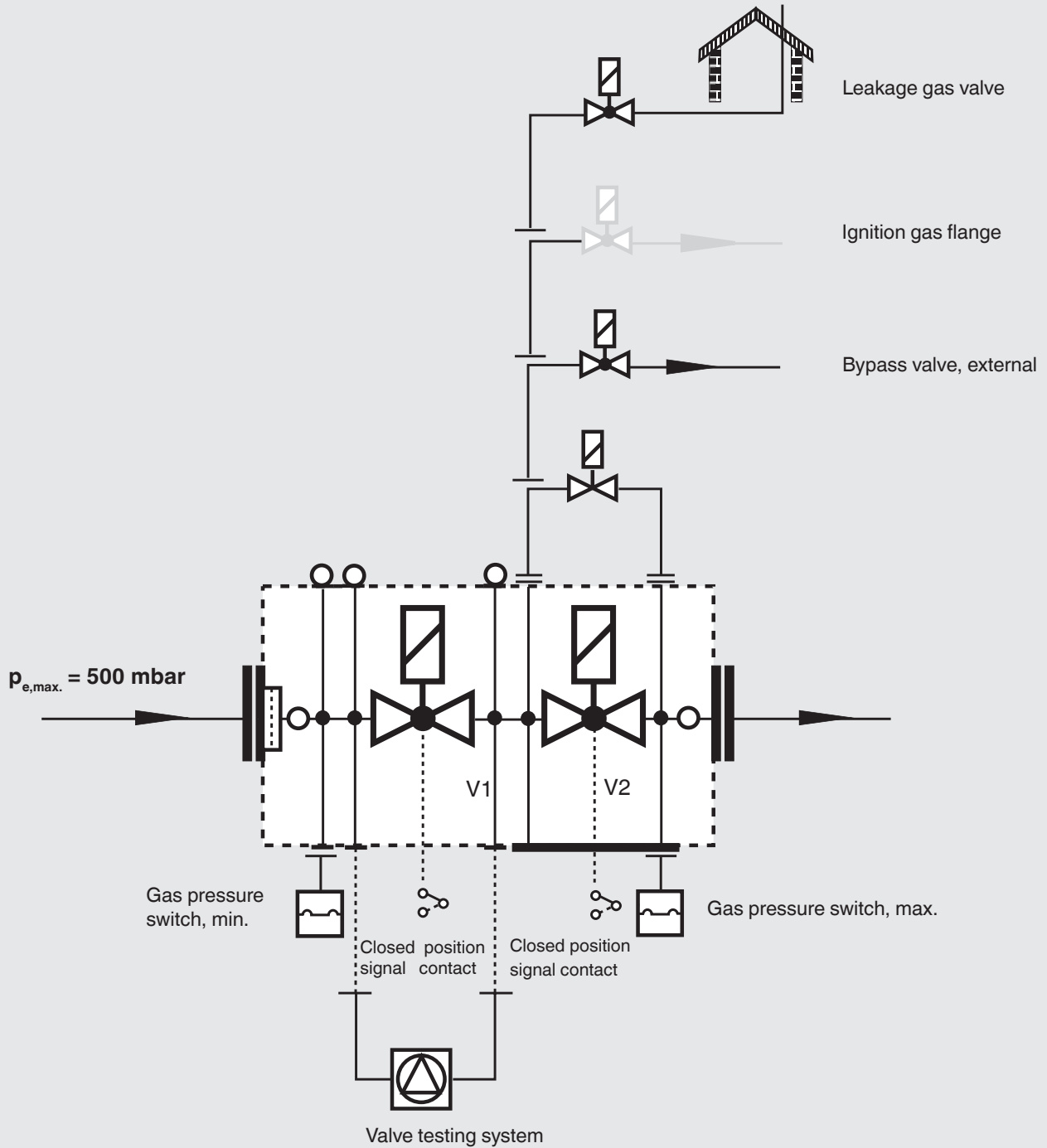

System accessories

The double solenoid valve has been designed for direct assembly of **DUNGS** system accessories and supplementary equipment.

Information on system accessories

Valve testing system VPS 504

Data sheet 8.10

Pressure limiter for multiple actuators ÜB, NB...A2

Data sheet 5.08

Compact pressure switch for multiple actuators GW...A5

Data sheet 5.02

Signal contact K01/1 for checking the closed position of valves

Data sheet 12.01

! If system accessories are assembled, it may not be possible to mount an additional device!

Double solenoid valve
 Nominal width
 Rp 2 (DN 50)
 DN 65 - DN 125

DMV/12
 DMV-D/12
 DMV-DLE/12

DUNGS®
 Combustion Controls

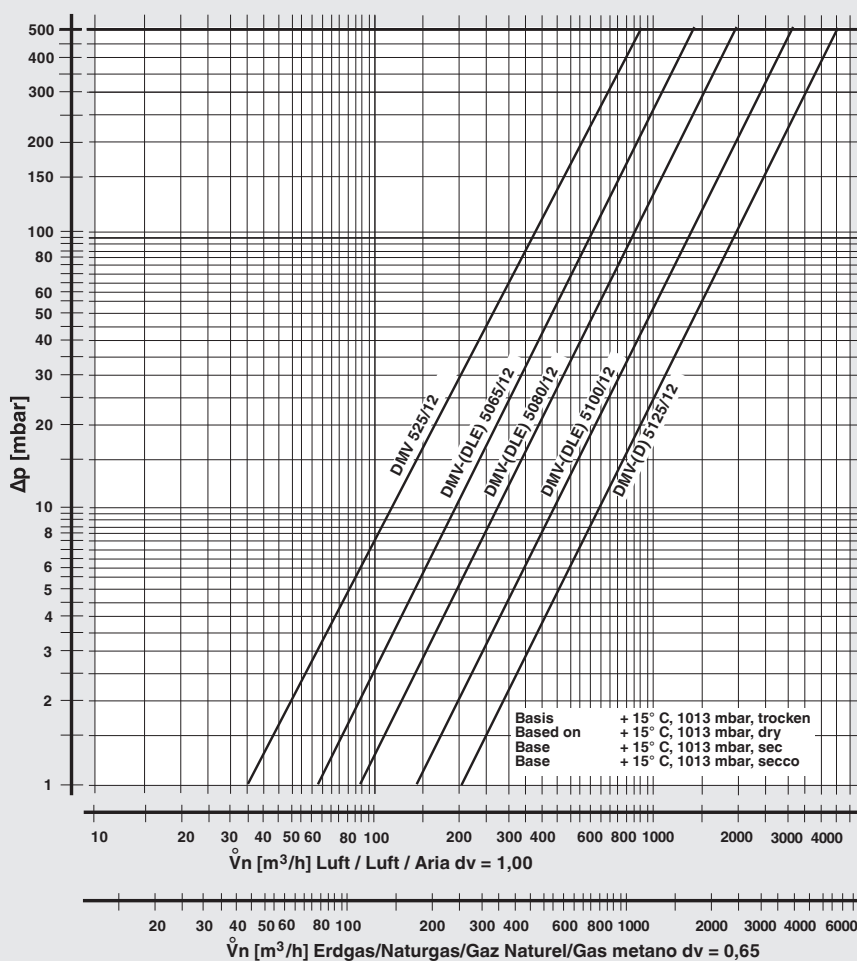

$$f = \sqrt{\frac{\text{Dichte Luft} / \text{Dichte des verwendeten Gases}}{\text{Spec. weight air} / \text{Spec. weight of gas used}}}$$

Dichte Luft
 Spec. weight air
 poids spécifique de l'air
 peso específico aria
 Dichte des verwendeten Gases
 Spec. weight of gas used
 poids spécifique du gaz utilisé
 peso específico del gas utilizzato

Gas type	Density [kg/m³]	d_v	f
Natural gas	0.81	0.65	1.24
Town gas	0.58	0.47	1.46
Liquefied gas	2.08	1.67	0.77
Air	1.24	1.00	1.00

$$\dot{V}_{\text{verwendetes Gas/gas used/gaz utilisé/gas utilizzato}} = \dot{V}_{\text{Luft/air/aria}} \times f$$

We reserve the right to make changes in the interest of technical progress.

Head Offices & Factory
 Karl Dungs GmbH & Co. KG
 Siemensstraße 6-10
 D-73660 Urbach, Germany
 Telefon +49 (0)7181-804-0
 Telefax +49 (0)7181-804-166

Postal address
 Karl Dungs GmbH & Co. KG
 Postfach 12 29
 D-73602 Schorndorf, Germany
 e-mail info@dungs.com
 Internet www.dungs.com