



## Burner controls

## LME...

**Burner controls for the supervision of 1- or 2-stage gas or gas / oil burners of small to medium capacity, intermittent operation with or without fan.**

**The LME... and this Data Sheet are intended for use by OEMs which integrate the burner controls in their products.**

### Use, features

Use	<p>LME... burner controls are used for the startup and supervision of 1- or 2-stage gas or gas / oil burners in intermittent operation. The flame is supervised by an ionization probe or flame detector QRA... with ancillary unit AGQ3...A27 for gas / oil forced draft burners or blue-burning flames with blue-flame detectors QRC...</p> <p>In terms of housing dimensions, the LME... are identical with the LGB... and LMG... burner controls (refer to «Type summary»).</p> <ul style="list-style-type: none"> <li>- For gas burners with or without fan to EN 298: 2003</li> <li>- For gas burners with fans conforming to EN 676</li> <li>- For oil burners to EN 230: 2005</li> </ul>
Features	<ul style="list-style-type: none"> <li>- Undervoltage detection</li> <li>- Air pressure supervision with functional check of the air pressure switch during startup and operation</li> <li>- Electrical remote reset facility</li> <li>- Multicolor indication of fault status and operational status messages</li> <li>- Limitation of the number of repetitions</li> <li>- Accurate control sequence thanks to digital signal handling</li> <li>- Controlled intermittent operation after 24 hours of continuous operation</li> </ul>

### Supplementary documentation

Product Range Overview LME..... Q7101

## Warning notes

---



**To avoid injury to persons, damage to property or the environment, the following warning notes must be observed!**

### **Do not to open, interfere with or modify the unit!**

- All activities (mounting, installation and service work, etc.) must be performed by qualified staff
- Before making any wiring changes in the connection area, completely isolate the plant from mains supply (all-polar disconnection). Ensure that the plant cannot be inadvertently switched on again and that it is indeed dead. If not observed, there is a risk of electric shock hazard
- Ensure protection against electric shock hazard by providing adequate protection for the burner control's connection terminals
- Check the connecting lines of the air pressure switch for short-circuits (connection terminals 3, 6 and 11)
- Press the lockout reset button / operation button of the LME... or the AGK20... lockout reset button extension only manually (applying a force of no more than 10 N) without using any tools or pointed objects
- Fall or shock can adversely affect the safety functions. Such units must not be put into operation, even if they do not exhibit any damage
- Each time work has been carried out (mounting, installation, service work, etc.), check to ensure that wiring is in an orderly state and make the safety checks as described in «Commissioning notes»

## Engineering notes

---

- When used in connection with actuators, there is no position feedback signal from the actuator to the burner control
- When used in connection with actuators, the requirements of applicable norms and regulations must be observed
- The running times of the actuators must match the burner control's program. An additional safety check of the burner control together with the actuators is required
- When substituting burner controls type LGB... or LMG... by LME..., the AGQ1... or AGQ2... ancillary unit must be replaced by the AGQ3...A27

## Mounting notes

---

- Ensure that the relevant national safety regulations are complied with

## Installation notes

- Always run the high ignition cables separate from the unit and other cables while observing the greatest possible distance
- Do not mix up live and neutral conductors
- Install switches, fuses, earthing, etc., in compliance with local regulations
- The connection diagrams show the burner controls with earthed neutral conductor. In networks with non-earthed neutral conductor and ionization current supervision, terminal 2 must be connected to the earth conductor via an RC unit (product no. ARC 4 668 9066 0). It must be made certain that local regulations are complied with (e.g. protection against electric shock hazard) since AC 120 V (50 / 60 Hz) or AC 230 V (50/60 Hz) mains voltage produces peak leakage currents of 2.7 mA
- Make certain that the maximum permissible current rating of the connection terminals will not be exceeded
- Do not feed external mains voltage to the control outputs of the unit. When testing the devices controlled by the burner control (fuel valves, etc.), the LME... must not be connected
- In the case of burners with no fan motor, an AGK25 must be connected to terminal 3 of the unit, or else the burner cannot reliably be started up
- For safety reasons, feed the neutral conductor to terminal 2. Connect the burner components (fan, ignition transformer and fuel valves) to the neutral distributor as shown below. The connection between neutral conductor and terminal 2 is pre-wired in the base

Example

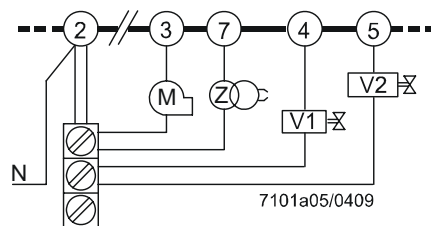

Legend

- V... Fuel valve
- M Fan motor
- Z Ignition transformer

Correct wiring of neutral conductors!

## Electrical connection of flame detectors

It is important to achieve practically disturbance- and loss-free signal transmission:

- Never run detector cables together with other cables
  - Line capacitance reduces the magnitude of the flame signal
  - Use a separate cable
- Observe the permissible length of the detector cables (refer to «Technical data»)
- The ionization probe and ignition electrode are not protected against electric shock hazard
- Locate the ignition electrode and the ionization probe such that the ignition spark cannot arc over to the ionization probe (risk of electrical overloads) and that it cannot adversely affect the supervision of ionization
- Insulation resistance
  - Must be a minimum of 50 M $\Omega$  between ionization probe and ground
  - Soiled detector holders reduce the insulation resistance, thus supporting creep currents
- Earth the burner in compliance with the relevant regulations; earthing the boiler alone does not suffice

## Commissioning notes

- When commissioning the plant for the first time or when doing maintenance work, make the following safety checks:

	<b>Safety check to be carried out</b>	<b>Anticipated response</b>
a)	Burner startup with previously interrupted line to the flame detector	<p>LME11... / LME41.051...: Max. 3 repetitions</p> <p>LME2... / LME41.052... / LME41.053... / LME41.054... / LME41.071... / LME41.09... / LME44...: Lockout at the end of safety time (TSA)</p>
b)	Burner operation with simulated loss of flame. For that purpose, cut off the fuel supply	<p>LME11... / LME41.051...:</p> <ul style="list-style-type: none"> <li>• Establishment of flame at the end of safety time (TSA) → Max. 3 repetitions</li> <li>• No establishment of flame at the end of safety time (TSA) → Lockout</li> </ul> <p>LME2... / LME44...: Lockout</p> <p>LME41.052... / LME41.053... / LME41.054... / LME41.071... / LME41.09...: Repetition</p>
c)	Burner operation with simulated air pressure failure	<p>Immediate lockout</p> <p>LME41...: Safety shutdown / restart</p>



Conformity to EEC directives  
 - Electromagnetic compatibility EMC (immunity)  
 - Directive for gas-fired appliances  
 - Low-voltage directive  
 - Directive for pressure devices

2004/108/EC  
 90/396/EEC  
 2006/95/EC  
 97/23/EC



ISO 9001: 2000  
 Cert. 00739



ISO 14001: 2004  
 Cert. 38233

**Identification code to EN 298 / EN 230**

LME11...	<b>F M C L X N</b>
LME21... / LME22... / LME23...	<b>F T L L X N</b>
LME41...	<b>A M C L X N</b>
LME44...	<b>A B L L X N</b>

Product no.				
LME11.230C2	---	X	X	---
LME11.330C2	---	X	X	X
LME21.130C1	X	X	X	---
LME21.130C2	X	X	X	X
LME21.230C2	X	X	X	X
LME21.330C1	X	X	X	---
LME21.330C2	X	X	X	X
LME21.350C1	X	X	X	---
LME21.350C2	X	X	X	X
LME21.550C2	X	X	X	X
LME22.131C2	X	X	X	X
LME22.231C2	X	X	X	X
LME22.232C2	X	X	X	X
LME22.233C2	X	X	X	X
LME22.331C1	X	X	X	---
LME22.331C2	X	X	X	X
LME23.331C2	X	X	X	X
LME23.351C2	X	X	X	X
LME41.051C2	---	X	X	---
LME41.052C2 *)	---	X	X	---
LME41.053C2 *)	---	X	X	---
LME41.054C2	---	X	X	---
LME41.071C2	---	X	X	---
LME41.091C2	---	X	X	---
LME41.092C2	---	X	X	---
LME44.056C2	---	X	X	X
LME44.057C1	---	X	X	---
LME44.057C2	---	X	X	X

\*) On request

**Service notes**

- Use the KF8872 service adapter for short periods of time only

## Lifetime

---

The burner control has a designed lifetime\* of 250,000 burner startup cycles which, under normal operating conditions in heating mode, correspond to approx. 10 years of usage (starting from the production date given on the type field). This lifetime is based on the endurance tests specified in standard EN 230 / EN 298 and the table containing the relevant test documentation as published by the European Association of Component Manufacturers (Afecon) ([www.afecor.org](http://www.afecor.org)).

The designed lifetime is based on use of the burner controls according to the manufacturer's Data Sheet. After reaching the designed lifetime in terms of the number of burner startup cycles, or the respective time of usage, the burner control is to be replaced by authorized personnel.

\* The designed lifetime is not the warranty time specified in the Terms of Delivery

## Disposal notes

---



The unit contains electrical and electronic components and must not be disposed of together with domestic waste.  
Local and currently valid legislation must be observed.

## Mechanical design

---

LME...

- Units of plug-in design like their predecessor types LGB... and LMG... (refer to «Dimensions»)
- The housing is made of impact-proof, heat-resistant and flame-retarding plastic. It is of plug-in design and engages audibly in the base
- The housing accommodates the
  - microcontroller for the control sequence and the control relays for load control
  - electronic flame signal amplifier (ionization)
  - lockout reset button with its integrated 3-color signal lamp (LED) for operational status and fault status messages and the socket for connecting the OCI400 interface adapter or the AGK20... lockout reset button extension.

Indication and diagnostics

- Multicolor indication for operational status and fault status messages
- Transmission of operational status and fault status messages and detailed service information via additional OCI400 interface adapter and ACS410 PC Windows software

Versions

- Burner capacity unlimited (thermal output on startup  $\leq 120$  kW)
- 3 repetitions in the event of loss of flame during operation (LME11... / LME41.051...)
- Repetition in the event of loss of flame during operation (LME41.052... / LME41.053... / LME41.054... / LME41.071... / LME41.091... / LME41.092...)

## Type summary (other types of burner control on request)

The product nos. given below applies to the LME... burner control without plug-in base and without flame detector. For ordering information on plug-in bases and other accessories, refer to «Ordering».

Flame detector	Product no.	Mains voltage	tw approx. s	t1 min. s	TSA max. s	t3n approx. s	t3 approx. s	t4 approx. s	t10 min. s <sup>3)</sup>	t11 min. s <sup>1)</sup>	t12 min. s <sup>1)</sup>	Repetition	Replacing...
<b>Burner controls for 1-stage burners (up to 120 kW output)</b>													
Ionization probe (ION)	LME11.230C2	AC 230 V	2.5	20	3	2.5	2	---	5	---	---	3x	---
	LME11.330C2	AC 230 V	2.5	30	3	2.5	2	---	5	---	---	3x	---
<b>Burner controls for 2-stage burners, without actuator control</b>													
Ionization probe (ION) or flame detector QRA... <sup>4)</sup> with AGQ3...A27	LME21.130C1	AC 120 V	2.5	7	3	2.5	2	8	5	---	---	---	LGB21.130A17
	LME21.130C2	AC 230 V	2.5	7	3	2.5	2	8	5	---	---	---	LGB21.130A27 LMG21.130B27
	LME21.230C2	AC 230 V	2.5	20	3	2.5	2	8	5	---	---	---	LGB21.230A27 LMG21.230B27
	LME21.330C1	AC 120 V	2.5	30	3	2.5	2	8	5	---	---	---	---
	LME21.330C2	AC 230 V	2.5	30	3	2.5	2	8	5	---	---	---	LGB21.330A27 LMG21.330B27
	LME21.350C1	AC 120 V	2.5	30	5	4.5	2	10	5	---	---	---	LGB21.350A17
	LME21.350C2	AC 230 V	2.5	30	5	4.5	2	10	5	---	---	---	LGB21.350A27 LMG21.350B27
	LME21.550C2	AC 230 V	2.5	50	5	4.5	2	10	5	---	---	---	LGB21.550A27
<b>Burner controls for 2-stage burners, with actuator control</b>													
Ionization probe (ION) or flame detector QRA... <sup>4)</sup> with AGQ3...A27	LME22.131C2	AC 230 V	2.5	7	3	2.5	3	8	3	12	12	---	LGB22.130A27 LMG22.130B27
	LME22.231C2	AC 230 V	2.5	20	3	2.5	3	8	3	12	12	---	---
	LME22.232C2	AC 230 V	2.5	20	3	2.5	3	8	3	16.5	16.5	---	LGB22.230A27 LMG22.230B27
	LME22.233C2	AC 230 V	2.5	20	3	2.5	3	8	3	30	30	---	LMG22.233B27
	LME22.331C1	AC 120 V	2.5	30	3	2.5	3	8	3	12	12	---	---
	LME22.331C2	AC 230 V	2.5	30	3	2.5	3	8	3	12	12	---	LGB22.330A27 LMG22.330B27
<b>Burner controls for 2-stage burners, with actuator control</b>													
Blue-flame detector QRC...	LME23.331C2	AC 230 V	2.5	30	3	2.5	3	8	3	12	12	---	LGB32.330A27
	LME23.351C2	AC 230 V	2.5	30	5	4.5	1	10	3	12	12	---	LGB32.350A27

### Legend

tw	Waiting time
TSA	Safety time
t1	Prepurge time
t3	Preignition time
t3n	Postignition time
t4	Interval between ignition «Off» and release of fuel valve 2 (V2)
t10	Specified time for air pressure signal
t11	Programmed opening time for actuator (SA)
t12	Programmed closing time for actuator (SA)
t22	2nd safety time

- 1) Max. running time available for actuator «SA»  
Actuator running time must be shorter
- 2) 2nd safety time (t22) + response time of flame relay
- 3) Approx. 180 s
- 4) Only used for AC 230 V

## Type summary (other types of burner control on request) [cont'd]

Flame detector	Product no.	Mains voltage	tw approx. s	t1' min. s	TSA max. s	t3n approx. s	t3 approx. s	t4 approx. s	t22 approx. s	Repetition	For replacing of
Burner controls for atmospheric burners											
Ionization probe (ION) or flame detector QRA... <sup>4)</sup> with AGQ3...A27	LME41.051C2	AC 230 V	2.5	1	5	4.5	1	---	---	3x	---
	LME41.052C2	AC 230 V	2.5	1	5	4.5	10	---	---	X	On request
	LME41.053C2	AC 230 V	2.5	10	5	4.5	1	---	---	X	On request
	LME41.054C2	AC 230 V	2.5	1	5	4.5	1	---	---	X	LGD12.05A27
	LME41.071C2	AC 230 V	2.5	10	10	9	1	---	---	X	---
	LME41.091C2	AC 230 V	2.5	1	10	9	10	---	---	X	LGA41.173A27
	LME41.092C2	AC 230 V	2.5	1	10	9	1	---	---	X	LGD12.01A27

Burner controls for atmospheric burners											
Ionization probe (ION) or flame detector QRA... <sup>4)</sup> with AGQ3...A27	LME44.056C2	AC 230 V	16	9	5	4.5	2	10	5	---	LGB41.255A27
	LME44.057C1	AC 120 V	16	9	5	4.5	2	10	8	---	LGB41.258A17
	LME44.057C2	AC 230 V	16	9	5	4.5	2	10	8	---	LGB41.258A27

### Legend

tw	Waiting time
TSA	Safety time
t1'	Purge time
t3	Preignition time
t3n	Postignition time
t4	Interval between ignition «Off» and release of fuel valve 2 (V2)
t10	Specified time for air pressure signal
t11	Programmed opening time for actuator (SA)
t12	Programmed closing time for actuator (SA)
t22	2nd safety time

- 1) Max. running time available for actuator «SA»  
Actuator running time must be shorter
- 2) Max. 65 s
- 3) Max. 180 s
- 4) Only used for AC 230 V



## Technical data

General unit data	Mains voltage	AC 120 V +10% / -15% AC 230 V +10% / -15%
	Mains frequency	50...60 Hz ±6%
	Power consumption	12 VA
	External primary fuse (Si)	Max. 10 A (slow)
	Mounting position	Optional
	Input current at terminal 12	Max. 5 A
	Weight	Approx. 160 g
	Safety class	I
	Degree of protection	IP40 (to be ensured through mounting)
	Perm. cable length terminal 1	Max. 1 m at a line capacitance of 100 pF/m (max. 3 m at 15 pF/m)
	Perm. cable length from QRA... to AGQ3...A27 (lay separate cable)	Max. 20 m at 100 pF/m
	Remote reset laid separately	Max. 20 m at 100 pF/m
	Perm. cable length terminals 8 and 10	Max. 20 m at 100 pF/m
	Perm. cable lengths other terminals	Max. 3 m at 100 pF/m

Perm. terminal load	At $\cos\varphi \geq 0.6$	At $\cos\varphi = 1$
- Terminal 3	Max. 2.7 A (15 A for max. 0.5 s → only LME2...)	Max. 3 A
- Terminals 4, 5, 7 and 9 (11)	Max. 1.7 A	Max. 2 A
- Terminal 10	Max. 1 A	Max. 1 A

Environmental conditions

<b>Storage</b>	DIN EN 60721-3-1
Climatic conditions	Class 1K3
Mechanical conditions	Class 1M2
Temperature range	-20...60 °C
Humidity	<95% r.h.
<b>Transport</b>	DIN EN 60 721-3-2
Climatic conditions	Class 2K2
Mechanical conditions	Class 2M2
Temperature range	-20...60 °C
Humidity	<95% r.h.
<b>Operation</b>	DIN EN 60 721-3-3
Climatic conditions	Class 3K3
Mechanical conditions	Class 3M3
Temperature range	-20... 60 °C
Humidity	<95% r.h.



**Caution!**  
Condensation, formation of ice and ingress of water are not permitted!

**Flame supervision  
with ionization probe**

	At mains voltage	
	UN = AC 120 V <sup>1)</sup>	UN = AC 230 V <sup>1)</sup>
Detector voltage between ionization probe and ground (AC voltmeter Ri ≥ 10 MΩ)	AC 50...120 V	AC 115...230 V
Switching threshold (limit values):		
Switching on (flame on) (DC ammeter Ri ≤ 5 kΩ)	≥ DC 1.5 μA	≥ DC 1.5 μA
Switching off (flame off) (DC ammeter Ri ≤ 5 kΩ)	≤ DC 0.5 μA	≤ DC 0.5 μA
Detector current required for reliable operation	≥ DC 3 μA	≥ DC 3 μA
Switching threshold in the event of poor flame during operation (LED flashes green)	Approx. DC 5 μA	Approx. DC 5 μA
Short-circuit current between ionization probe and ground (AC ammeter Ri ≤ 5 kΩ)	Max. AC 50...150 μA	Max. AC 100...300 μA

<sup>1)</sup> For applications outside the European Community, operation at mains voltage AC 120 V / AC 230 V ±10% is ensured

 **Note!**  
With the same quality of flame, the detector current with the LME... may be different from than with LMG... / LGB...

Flame supervision with ionization is accomplished by making use of the conductivity and rectifying effect of the flame. The flame signal amplifier only responds to the DC current component of the flame signal. A short-circuit between ionization probe and ground causes the burner to initiate lockout.

Measuring circuit

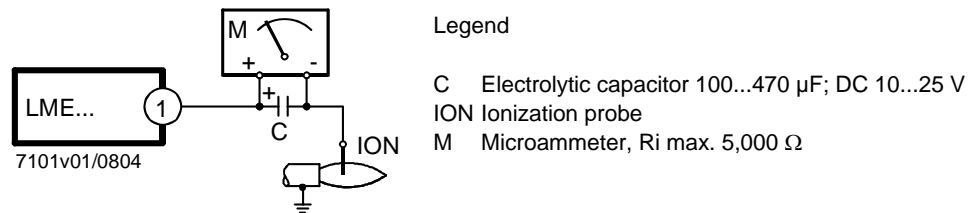

For detector currents, refer to «Technical data».

Technical data (cont'd)

Flame supervision with AGQ3...A27 and UV detector QRA...

Mains voltage	AC 230 V +10% / -15%
Mains frequency	50...60 Hz ±6%
Perm. cable length from QRA... to AGQ3...A27 (lay separate cable)	Max. 20 m
Perm. cable length from AGQ3...A27 to LME...C2	Max. 2 m
Weight of AGQ3...A27	Approx. 140 g
Perm. mounting position	Optional
Degree of protection	IP40, to be ensured through mounting
Power consumption	4.5 VA

	At mains voltage U <sub>n</sub>	
	AC 220 V	AC 240 V
<b>Detector voltage at QRA... (with no load)</b>		
Terminal 3 off (refer to control sequence)	DC 400 V	DC 400 V
Terminal 3 on (refer to control sequence)	DC 300 V	DC 300 V
<b>Detector voltage Load by DC measuring instrument R<sub>i</sub> &gt;10MΩ</b>		
Terminal 3 off (refer to control sequence)	DC 380 V	DC 380 V
Terminal 3 on (refer to control sequence)	DC 280 V	DC 280 V
<b>DC current detector signals with UV detector QRA...</b>		
Measurement at the UV detector QRA...	Min. required	Max. possible
	200 µA	500 µA

Ancillary unit AGQ3...A27

In connection with LME...C2 burner controls, use of UV ancillary unit AGQ3...A27 is mandatory.

Correct functioning of aged UV cells can be checked as UV test with a higher supply voltage across the UV cell after controlled shutdown until terminal 3 on.

Connection diagram

Measuring circuit for measuring the UV detector current

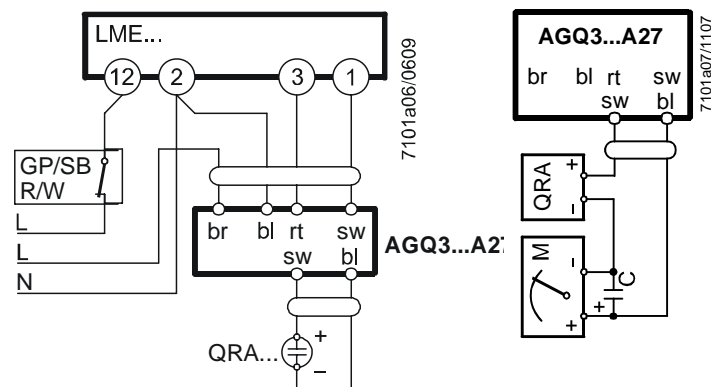

Measurement made at the UV detector QRA...

Legend

C	Electrolytic capacitor 100...470 µF; DC 10...25 V	bl	Blue
M	Microammeter R <sub>i</sub> max. 5,000 Ω	br	Brown
QRA...	Flame detector	gr	Grey
GP	Pressure switch	rt	Red
SB	Safety limit thermostat	sw	Black
R	Control thermostat or pressurestat		
W	Limit thermostat or pressurestat		

**Flame supervision with QRC...**  
(only LME23...)

	Detector current required (with flame)	Perm. detector current (without flame)	Possible detector current with flame (typically)
<b>QRC...</b>	Min. 70 µA	Max. 5.5 µA	Max. 100 µA

The values given in the table above only apply under the following conditions:  
 - Mains voltage AC 120 V / AC 230 V  
 - Ambient temperature 23 °C

Green LED for operational status indication

	Detector current in operation: - Flame signal instable - Green LED flashing	Detector current in operation: - Flame signal stable - Green LED steady on
<b>QRC...</b>	<45 µA	>45 µA

The values given in the table above only apply under the following conditions:  
 - Mains voltage AC 120 V / AC 230 V  
 - Ambient temperature 23 °C

Measuring circuit for detector current

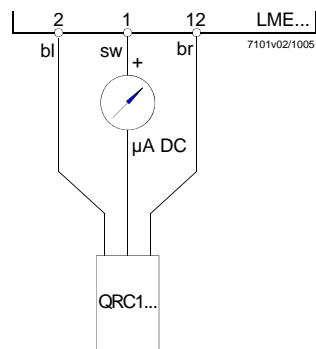

Legend

- µA DC DC microammeter with an internal resistance of  $R_i = \text{max. } 5 \text{ k}\Omega$
- bl Blue
- sw Black
- br Brown

As an alternative to detector current measurement, the OCI400 / ACS410 diagnostics tool can be used. In that case, the DC microammeter is not required.

**Functions**

**Preconditions for burner startup**

- Burner control must be reset
- All contacts in the line are closed, request for heat
- No undervoltage
- Air pressure switch «LP» must be in its no-load position
- Fan motor or AGK25 is closed (not at LME4...)
- Flame detector is darkened and there is no extraneous light

LME41...

- Air pressure switch «LP» must be in its no-load position or DBR1

LME44...

- CPI in its no-load position or DBR2

**Undervoltage**

- Safety shutdown from the operating position takes place should mains voltage drop below about AC 85 V (at  $U_N = \text{AC } 120 \text{ V}$ )
- Restart is initiated when mains voltage exceeds about AC 90 V (at  $U_N = \text{AC } 120 \text{ V}$ )
- Safety shutdown from the operating position takes place should mains voltage drop below about AC 175 V (at  $U_N = \text{AC } 230 \text{ V}$ )
- Restart is initiated when mains voltage exceeds about AC 185 V (at  $U_N = \text{AC } 230 \text{ V}$ )

**Controlled intermittent operation**

After no more than 24 hours of continuous operation, the burner control will initiate automatic controlled shutdown followed by a restart.

**Functions (cont'd)**

Control sequence in the event of fault      If lockout occurs, the outputs for the fuel valves, the burner motor and the ignition equipment will immediately be deactivated (<1 second).

Cause	Response
Mains failure	Restart
Voltage below undervoltage threshold	Safety shutdown
Voltage above undervoltage threshold	Restart
Extraneous light during prepurge time (t1)	Lockout
Extraneous light during waiting time (tw)	Prevention of startup, lockout after 30 seconds at the latest  LME41.051..., LME41.054..., LME41.092...: Prevention of startup
No flame at the end of safety time (TSA)	LME11..., LME41.051...: Max. 3 repetitions, followed by lockout at the end of safety time (TSA)  LME2..., LME41.052..., LME41.053..., LME41.054..., LME41.071..., LME41.09...: Lockout at the end of safety time (TSA)
Loss of flame during operation	LME11..., LME41.051...: <ul style="list-style-type: none"> <li>• Establishment of flame at the end of safety time (TSA) → Max. 3 repetitions</li> <li>• No establishment of flame at the end of safety time (TSA) → Lockout</li> </ul> LME2...: Lockout  LME41.052..., LME41.053..., LME41.054..., LME41.071..., LME41.09...: Repetition
Air pressure switch (LP) welded in working position - Error with valve proving (only in conjunction with LDU11...)  LME41...: No reaction	Prevention of startup, lockout after 65 seconds at the latest
Air pressure switch (LP) welded in no-load position  LME41...: Air pressure switch (LP) welded in no-load position or no connection (jumper) between terminal 3 and terminal 11	Lockout approx. 180 seconds after completion of specified time (t10)
No air pressure signal after completion specified time (t10)  LME41...: No air pressure signal after completion specified time (t10) or breakdown of jumper terminal 3 / terminal 11	Lockout  LME41...: Safety shutdown / restart
CPI contact is open during waiting time (tw)	Prevention of startup, lockout after 60 seconds at the latest

In the event of lockout, the LME... remains locked and the red signal lamp (LED) will light up. The burner control can immediately be reset. This state is also maintained in the case of mains failure.

Resetting the burner control

When lockout occurs, the burner control can immediately be reset. To do this, press the lockout reset button for about 1 second (<3 seconds). The LME... can only be reset when all contacts in the line are closed and when there is no undervoltage.

Limitation of repetitions  
(only LME11...,  
LME41.051...)

If no flame is established at the end of safety time (TSA), or if the flame is lost during operation, a maximum of 3 repetitions per controlled startup can be performed via control thermostat or pressurestat (R), or else lockout will be initiated. Counting of repetitions is restarted each time a controlled startup via control thermostat or pressurestat (R) takes place.

## Operation, indication, diagnostics

Operation

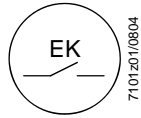

7101201/0804

Lockout reset button (EK) is the key operating element for resetting the burner control and for activating / deactivating the diagnostics functions.

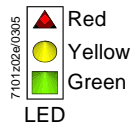

7101202e/0305

The multicolor signal lamp (LED) in the lockout reset button is the key indicating element for visual diagnostics and interface diagnostics.

Both lockout reset button (EK) and signal lamp (LED) are located under the transparent cover of the lockout reset button.

There are 2 diagnostics choices:

1. Visual diagnostics: Operational status indication or diagnostics of the cause of fault.
2. Interface diagnostics: With the help of the OCI400 interface adapter and the ACS410 PC software or flue gas analyzers of different makes.

Visual diagnostics:

In normal operation, the different operating states are indicated in the form of color codes according to the color code table given below.

Operational status indication

During startup, status indication takes place according to the following table:

Color code table for multicolor signal lamp (LED)		
Status	Color code	Color
Waiting time «tw», other waiting states	○.....	Off
Ignition phase, ignition controlled	● ○ ● ○ ● ○ ● ○ ● ○ ●	Flashing yellow
Operation, flame ok	□.....	Green
Operation, flame not ok	□ ○ □ ○ □ ○ □ ○ □ ○	Flashing green
Extraneous light on burner startup	□ ▲ □ ▲ □ ▲ □ ▲ □ ▲	Green-red
Undervoltage	● ▲ ● ▲ ● ▲ ● ▲ ● ▲	Yellow-red
Fault, alarm	▲.....	Red
Error code output (refer to «Error code table»)	▲○ ▲○ ▲○ ▲○	Flashing red
Interface diagnostics	▲ ▲ ▲ ▲ ▲ ▲ ▲ ▲	Red flicker light

Legend

- ..... Steady on
- Off
- ▲ Red
- Yellow
- Green

**Operation, indication, diagnostics (cont'd)**

Diagnostics of the cause of fault

After lockout, the red fault signal lamp LED will remain steady on. In that condition, visual diagnostics of the cause of fault according to the error code table can be activated by pressing the lockout reset button for more than 3 seconds. Pressing the reset button again for at least 3 seconds, interface diagnostics will be activated. Interface diagnostics works only if the AGK20... lockout reset button extension is not fitted. If, by accident, interface diagnostics has been activated, in which case the slightly red light of the signal lamp LED flickers, it can be deactivated by pressing again the lockout reset button for at least 3 seconds. The instant of switching over is indicated by a yellow light pulse.

The following sequence activates the diagnostics of the cause of fault:

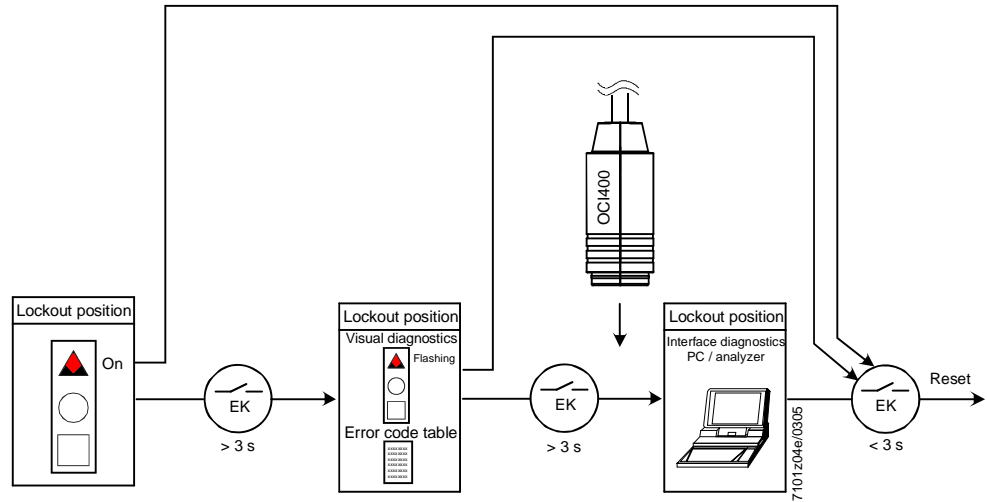

Error code table		
Red blink code of signal lamp (LED)	Alarm (AL) at term. 10	Possible cause
2 blinks	On	No establishment of flame at the end of safety time (TSA) - Faulty or soiled fuel valves - Faulty or soiled flame detector - Poor adjustment of burner, no fuel - Faulty ignition equipment
3 x blinks	On	Air pressure switch (LP) faulty - Loss of air pressure signal after specified time (t10) - Air pressure switch (LP) welded in normal position
4 blinks	On	Extraneous light when burner is started up
5 blinks	On	Time out air pressure switch (LP) - Air pressure switch (LP) welded in working position - Error with bei valve proving (only in conjunction with LDU11...)
6 blinks	On	Free
7 blinks	On	Too many losses of flame during operation (limitation of repetitions) - Faulty or soiled fuel valves - Faulty or soiled flame detector - Poor adjustment of burner
8 x blinks	On	Free
9 blinks	On	Free
10 blinks	Off	Wiring error or internal error, output contacts, other faults
14 blinks	On	CPI contact not closed

- During the time the cause of fault is diagnosed, the control outputs are deactivated
- Burner remains shut down
  - External fault indication remains deactivated
  - Fault status signal alarm (AL) at terminal 10, according to the error code table

The diagnostics of the cause of fault is quit and the burner switched on again by resetting the burner control. Press the lockout reset button for about 1 second (<3 seconds).



Connection diagram and control sequence of LME11...

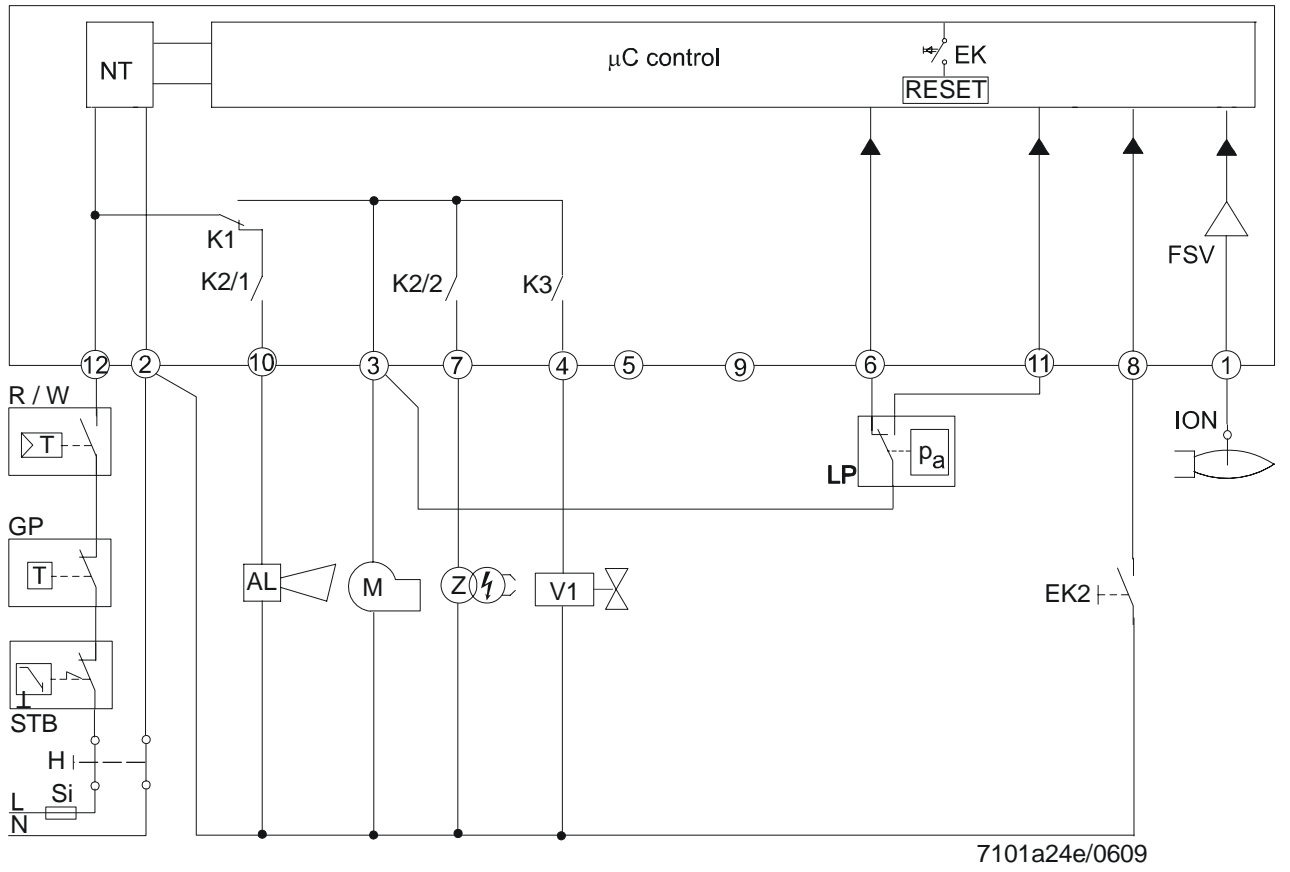

7101a24e/0609

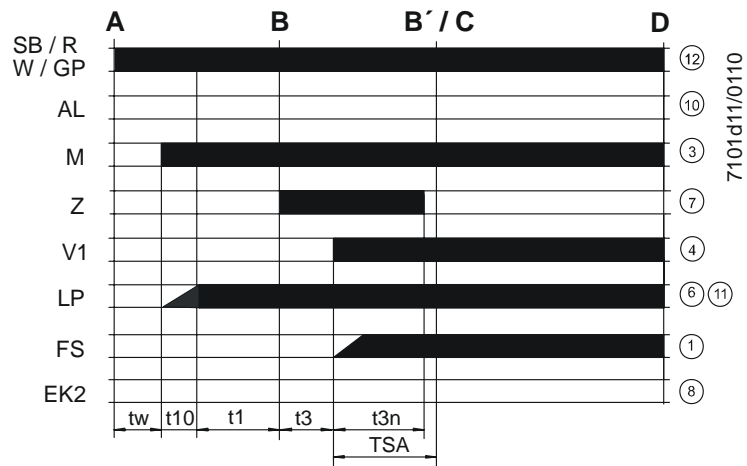

7101d11/0110

Connection diagram and control sequence of LME21...

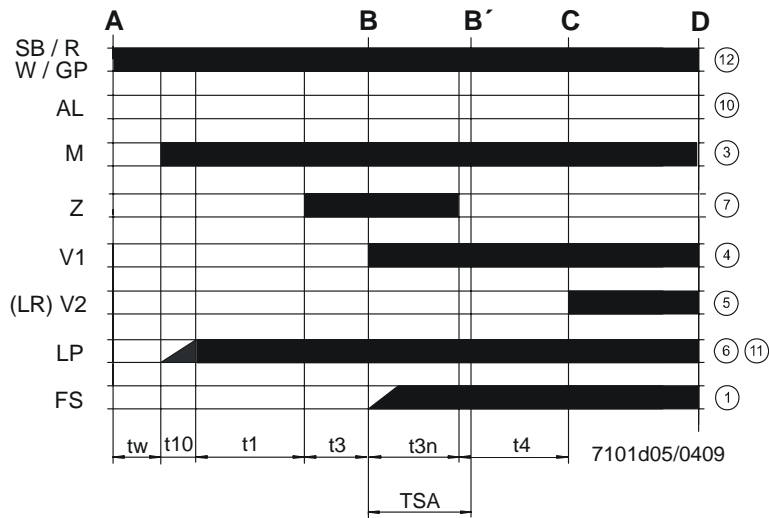
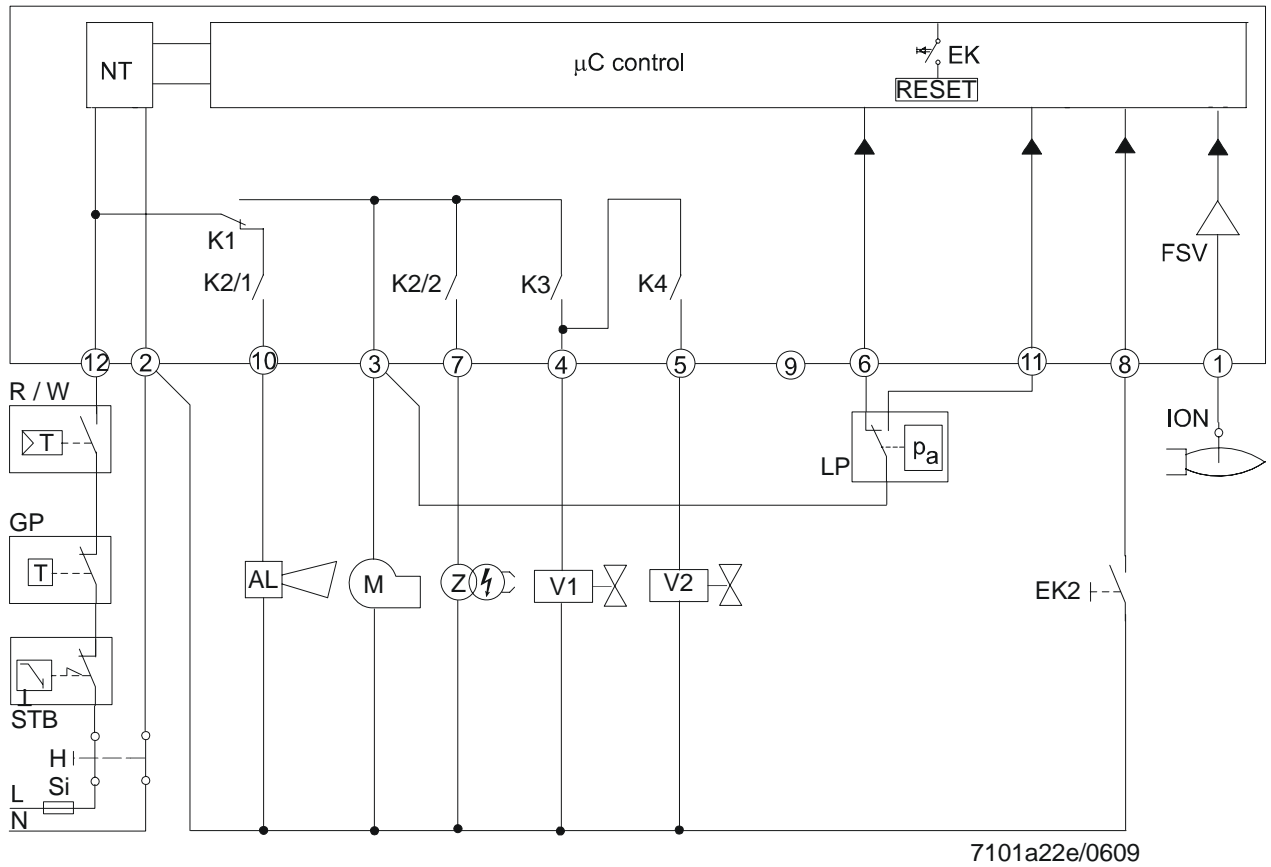

Application examples only LME11... / LME21... / LME22...



**Caution!**  
The connection diagrams shown are merely examples which must be verified in the individual case depending on the application!

Burner without fan and without air pressure switch «LP»

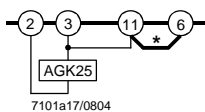

Only for burner with fan control via auxiliary contactor (HS) with air pressure switch (LP)

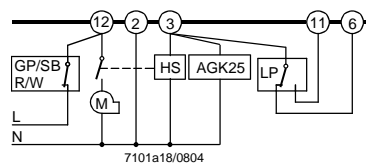

\* **Note:** Different from LGB...



**Caution!**  
 The connection diagrams shown are merely examples which must be verified in the individual case depending on the application!

Control of actuators of 2-stage or 2-stage modulating burners. Controlled prepurging ( $t_1$ ) with low-fire air volume. Same low-fire actuator position during startup and operation.

For information about actuators (SA):  
 SQN3...: Refer to Data Sheet N7808  
 SQN7...: Refer to Data Sheet N7804  
 SQN9...: Refer to Data Sheet N7806

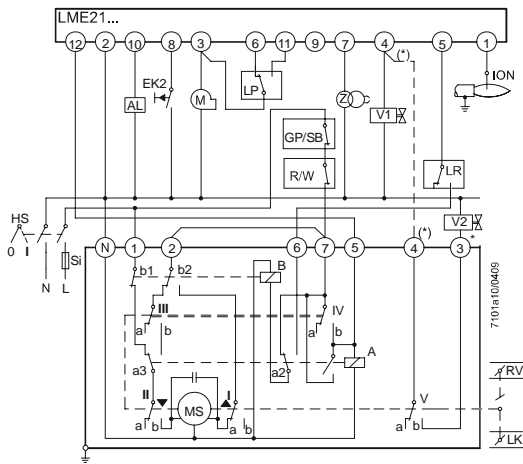
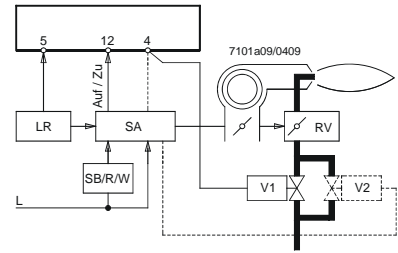

**SQN3...121... / 2-stage control**

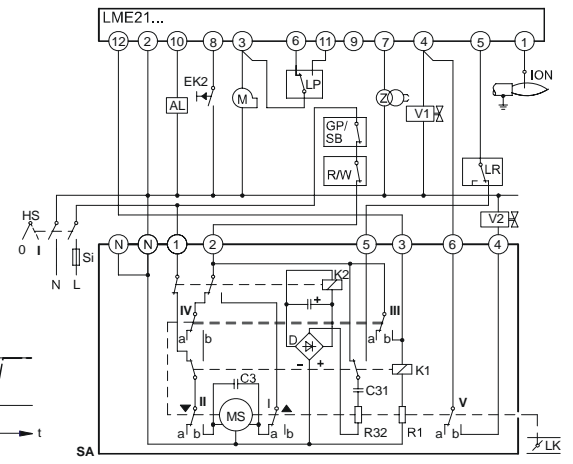

**SQN91.140... / 2-stage control**

**\* Note**

With 2-stage modulating burners (with gas regulation damper (RV), fuel valve 2 (V2) and the dotted connection between terminals (\*) are not required.

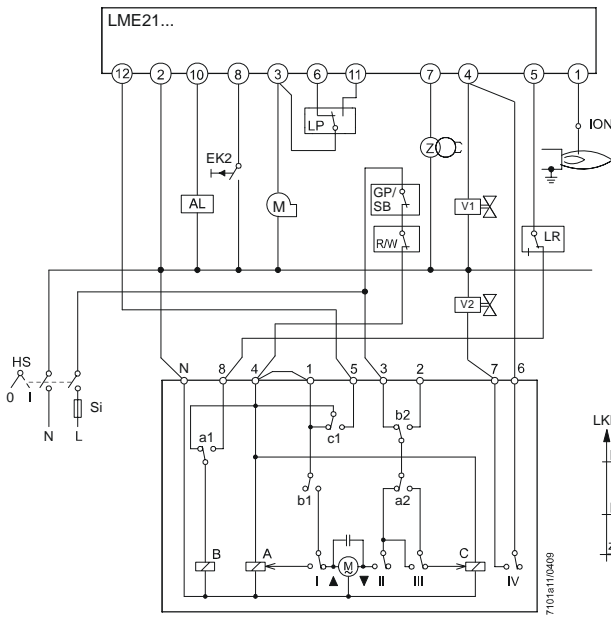

**SQN7...244 / 2-stage control**

# Connection diagram and control sequence of LME22... / LME23...

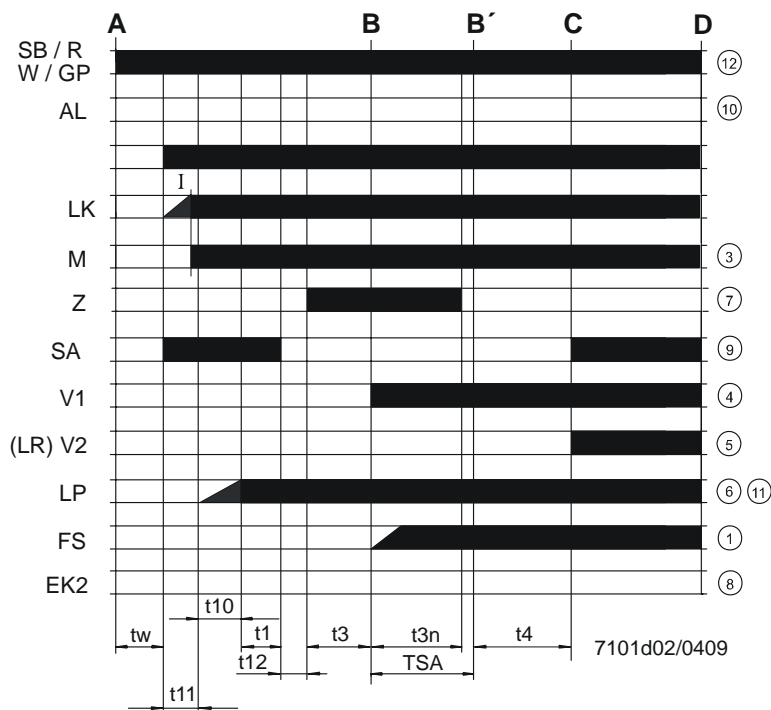
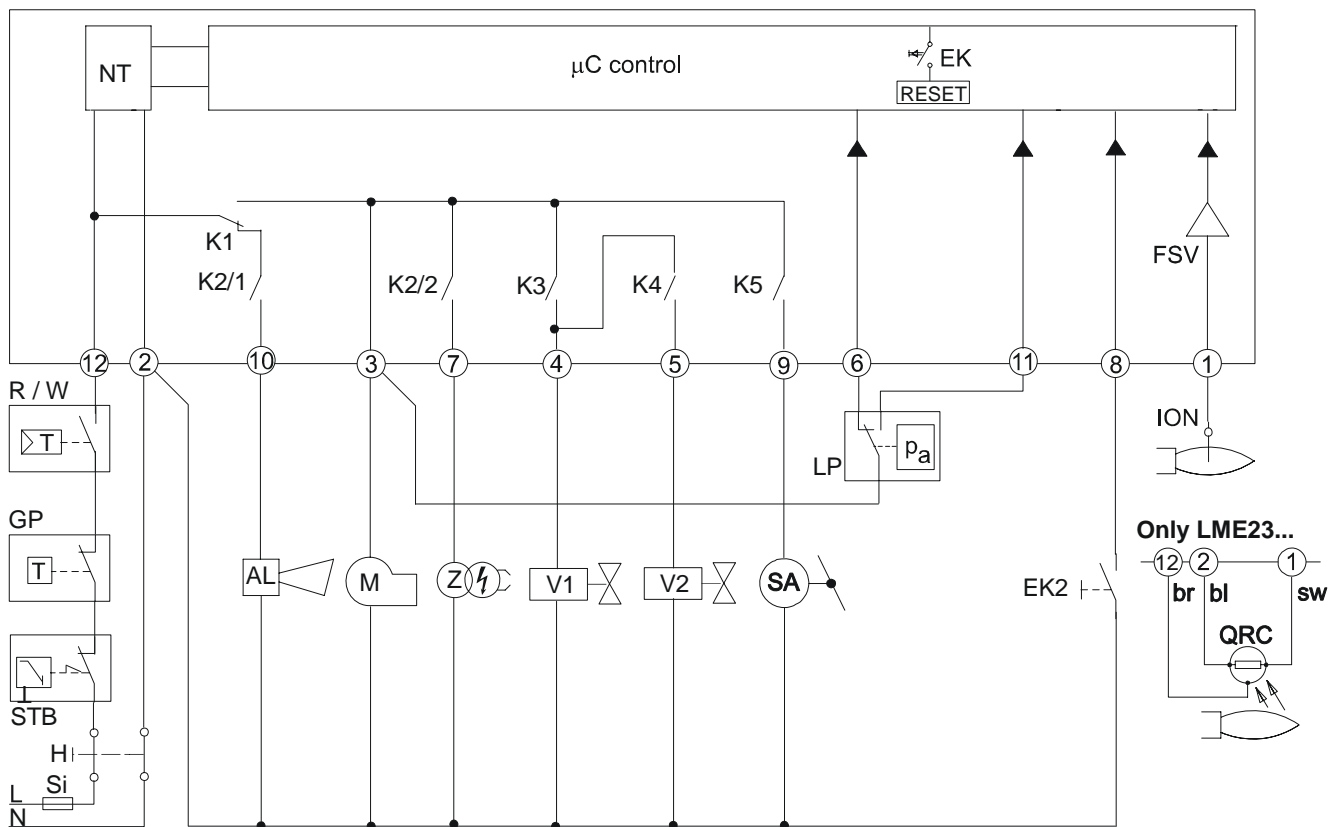



**Caution!**  
The connection diagrams shown are merely examples which must be verified in the individual case depending on the application!

Control of actuators of 2-stage or 2-stage modulating burners. Controlled prepurging (t1) with high-fire air volume.

For information about actuators (SA):  
SQN3...: Refer to Data Sheet N7808  
SQN7...: Refer to Data Sheet N7804  
SQN9...: Refer to Data Sheet N7806

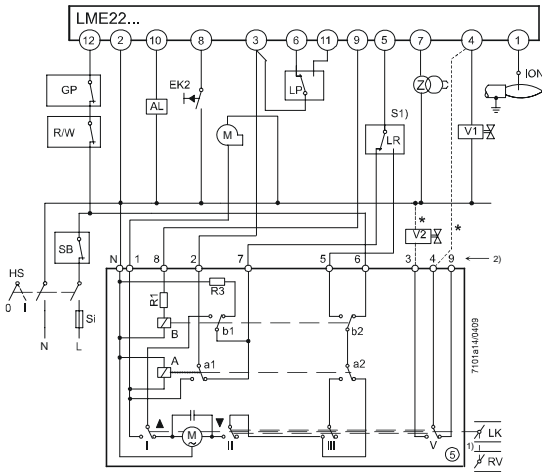
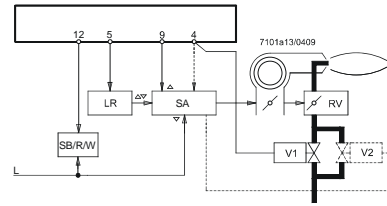

**SQN3...151... or SQN3...251...**

**\* Note**

With 2-stage modulating burners (with gas regulation damper (RV)), fuel valve 2 (V2) and the dotted connection between terminals (\*) are not required.

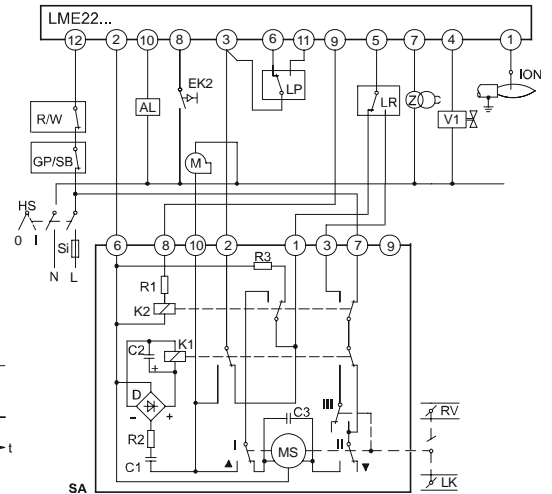

**SQN90.220... / 2-stage modulating control**

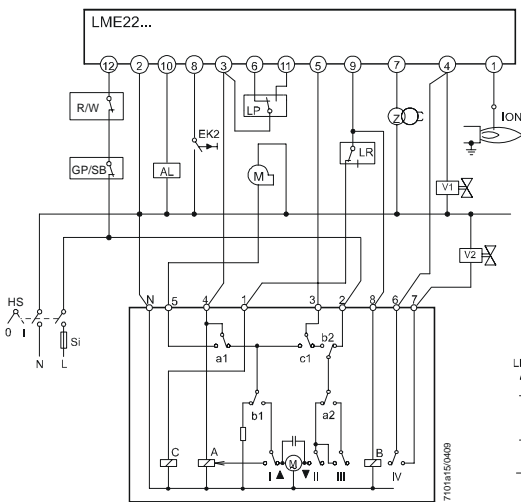

**SQN7...454 / 2-stage control  
1-wire control**

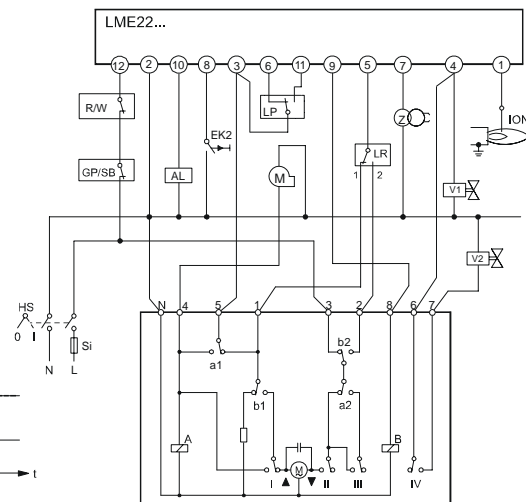

**SQN7...424 / 2-stage control  
2-wire control**

# Connection diagram and control sequence of LME41...

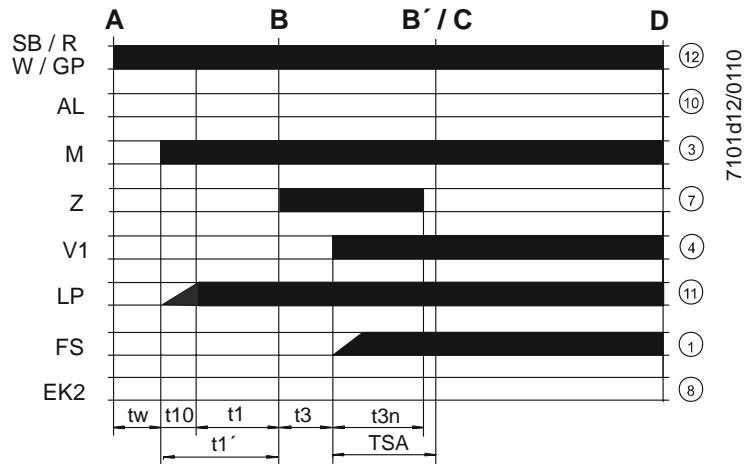
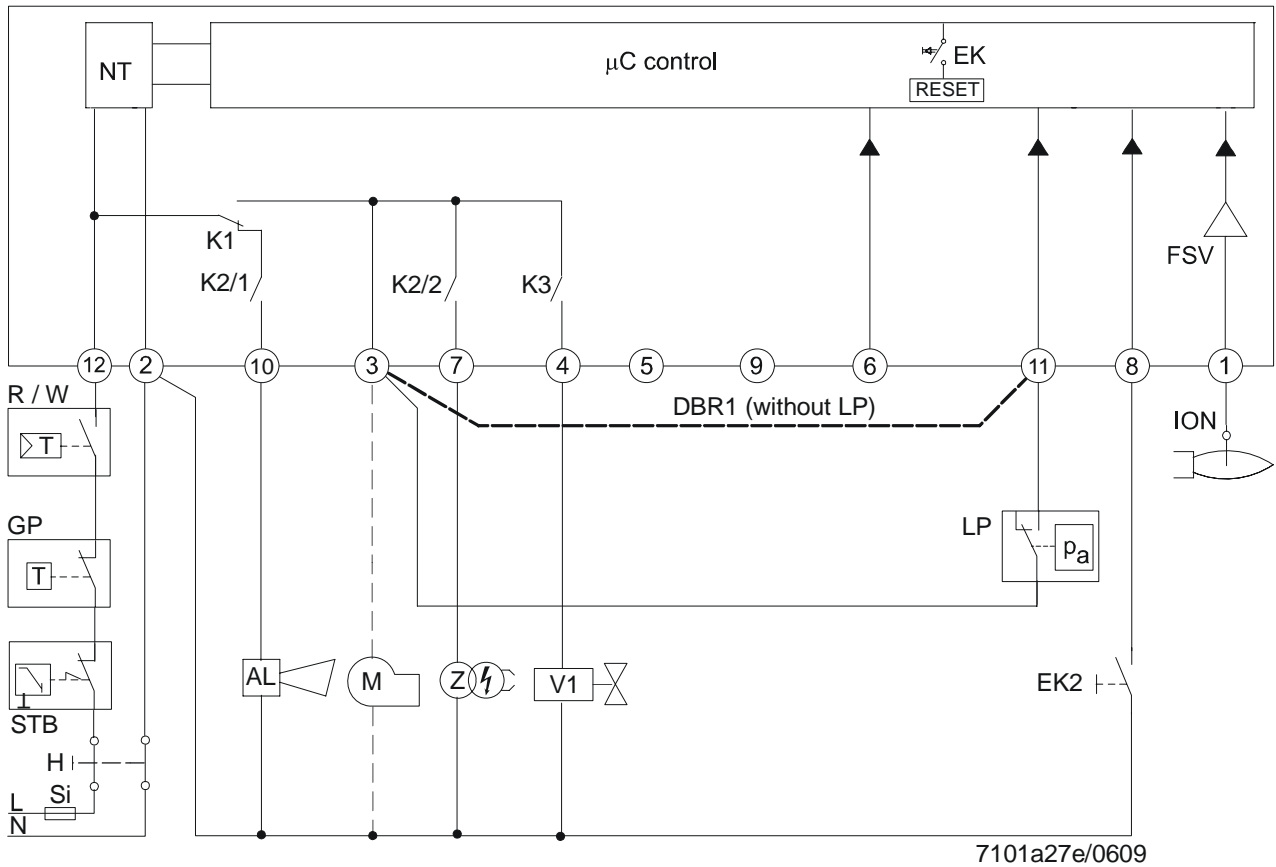

Connection diagram and control sequence of LME44...

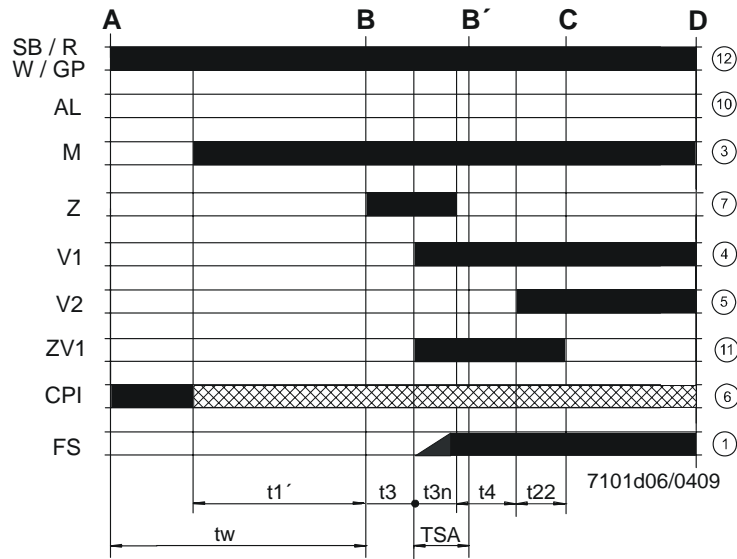
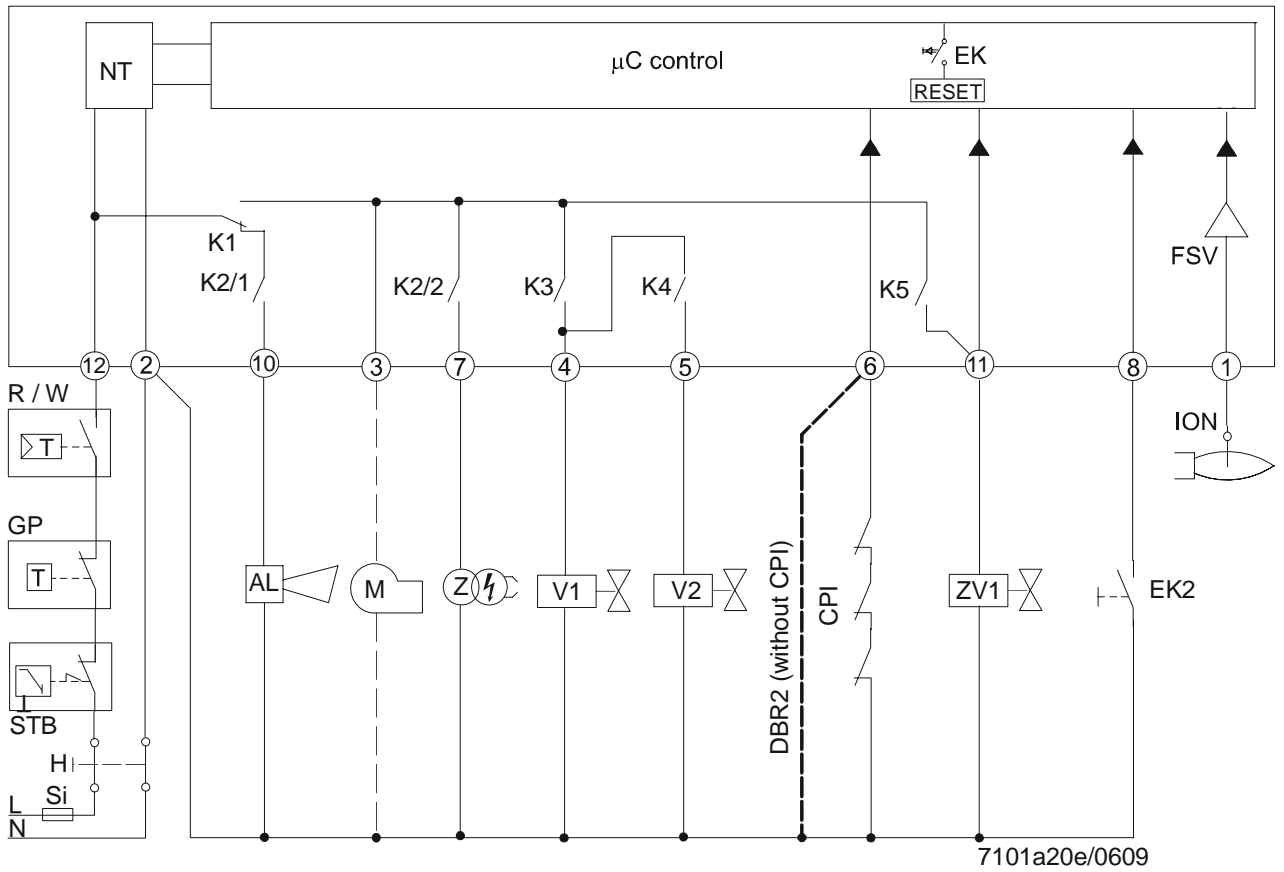

## Application 1

- LME21.xxxC... / LME22.xxxC... with LDU11... valve proving
- Before startup of burner
- In the case of plants without vent pipe to atmosphere

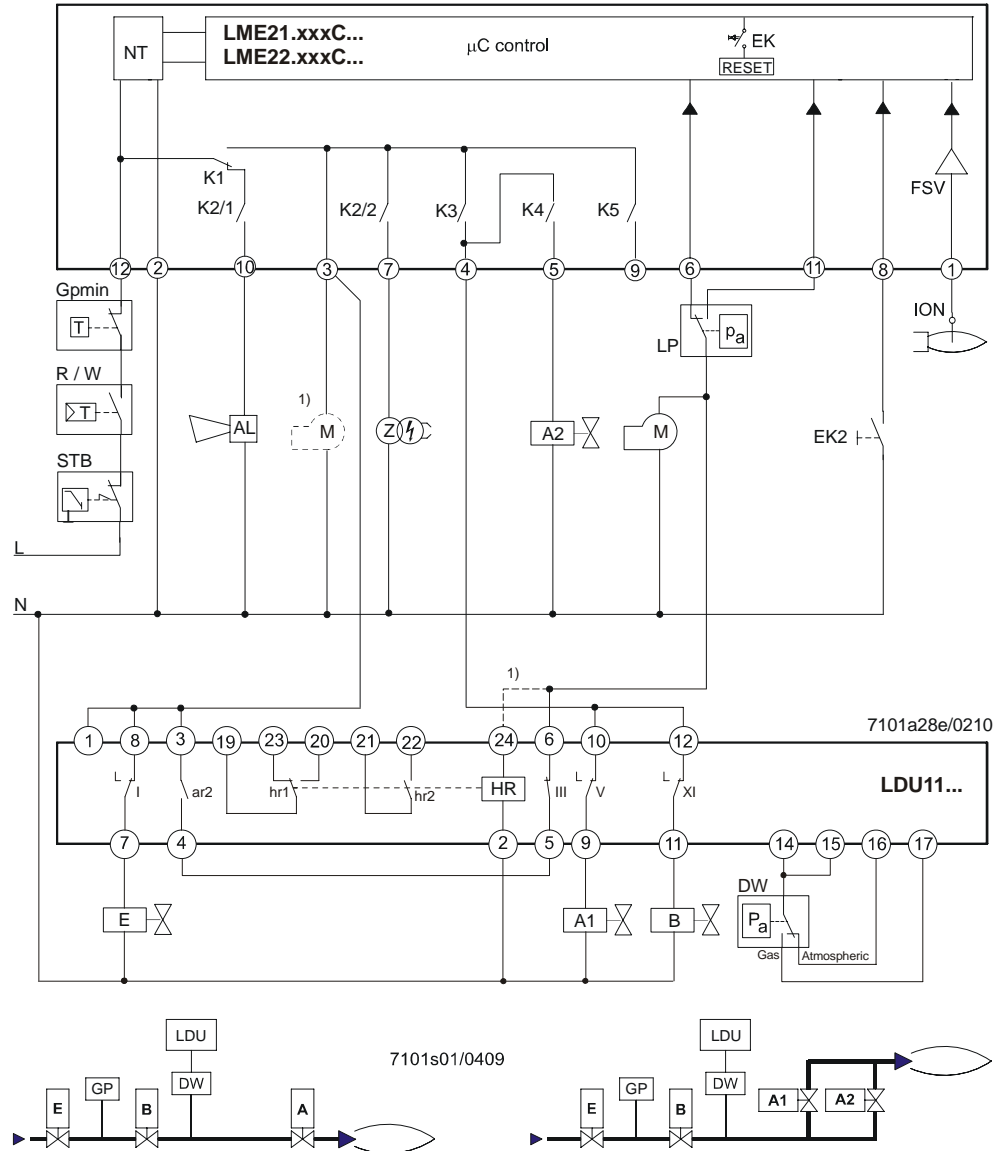

1) Fan motor connected to terminal 3 of the LME21.xxxC... / LME22.xxxC...

- Valve proving is started each time the system is switched on, with connection of terminal 3, after controller ON or after lockout
- If the LDU11... initiates lockout, valve proving can take up to 160 seconds. Therefore, the maximum permissible response time of the air pressure switch is 180 seconds
- With the LDU11..., faults during valve proving lead to lockout and, with the LME21.xxxC... / LME22.xxxC..., to lockout due to air pressure switch timeout (blink code 03)



### Note!

- A faulty air pressure switch (switch does not make) leads to lockout (blink code 03) on completion of the pressure switch response time of 180 seconds and can be distinguished from lockout due to faulty valve proving only because the LDU11... did not go to lockout
- The fan motor can be connected either to terminal 3 in connection with a link between terminals 6 and 24 of the LDU11... (motor active during valve proving) or to terminal 6 of the LDU11... (motor active on completion of successful valve proving)



- LME21.xxxC... / LME22.xxxC... with LDU11... valve proving
- Valve supervision before startup of burner
- In the case of plants with vent pipe to atmosphere

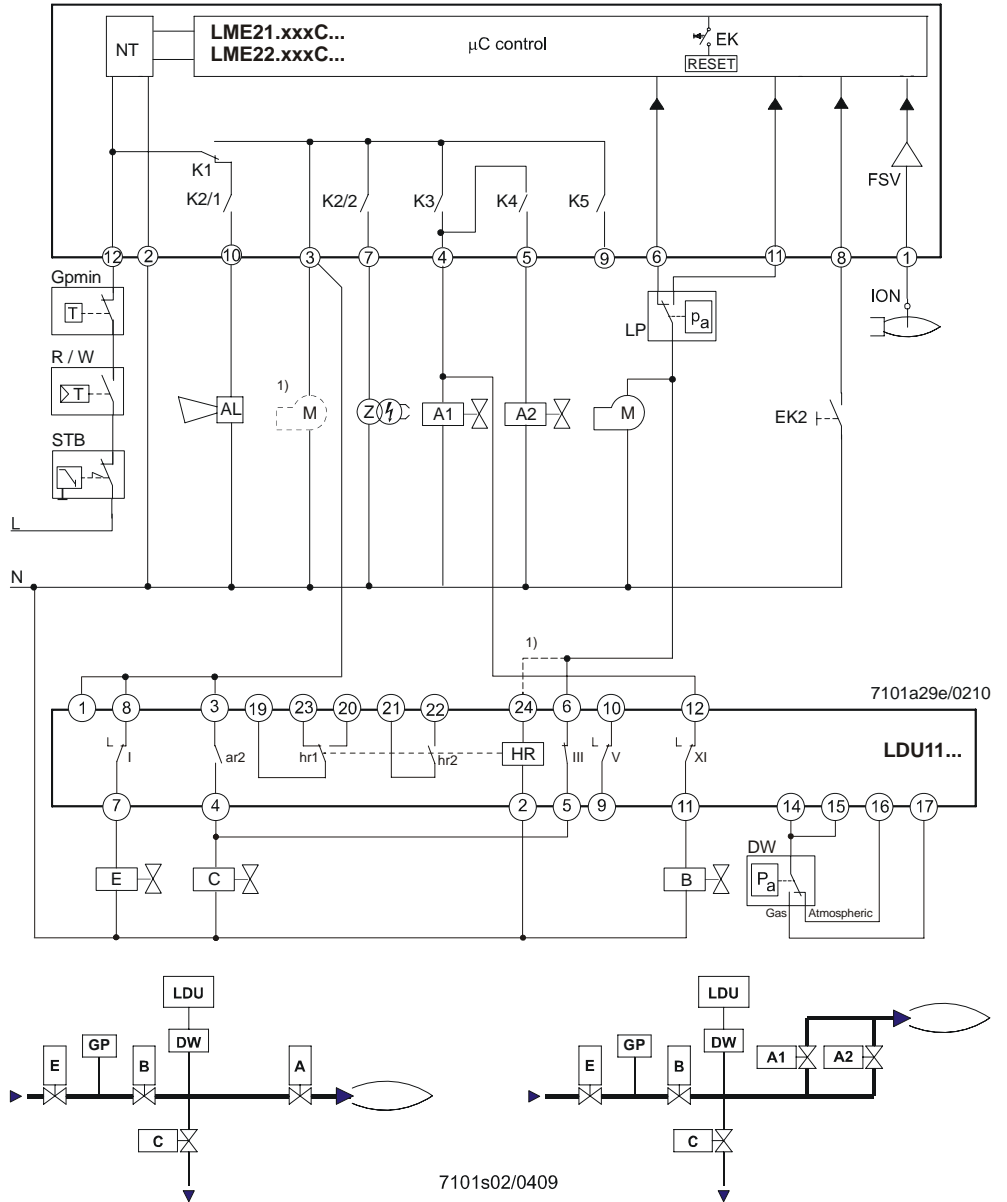



1) Fan motor connected to terminal 3 of the LME21.xxxC... / LME22.xxxC...

- Valve proving is started each time the system is switched on, with connection of terminal 3, after controller ON or after lockout
- If the LDU11... initiates lockout, valve proving can take up to 160 seconds. Therefore, the maximum permissible response time of the air pressure switch is 180 seconds
- With the LDU11..., faults during valve proving lead to lockout and, with the LME21.xxxC... / LME22.xxxC..., to lockout due to air pressure switch timeout (blink code 03)



- **Note!**  
A faulty air pressure switch (switch does not make) leads to lockout (blink code 03) on completion of the pressure switch response time of 180 seconds and can be distinguished from lockout due to faulty valve proving only because the LDU11... did not go to lockout
- The fan motor can be connected either to terminal 3 in connection with a link between terminals 6 and 24 of the LDU11... (motor active during valve proving) or to terminal 6 of the LDU11... (motor active on completion of successful valve proving)

## Legend

AGK25...	PTC resistor
AL	Error message (alarm)
BCI	Burner Communication Interface
V...	Fuel valve
CPI	Closed Position Indicator
DW	Pressure switch valve proving
DBR...	Wire link
EK	Lockout reset button (internal)
EK2	Remote lockout reset button
ION	Ionization probe
FS	Flame signal
FSV	Flame signal amplifier
GP	Gas pressure switch
H	Main switch
HS	Auxiliary contactor, relay
ION	Ionization probe
K1...4	Internal relays
KL	Low-fire
LK	Air damper
LKP	Air damper position
LP	Air pressure switch
LR	Load controller
M	Fan motor
MS	Synchronous motor
NL	Nominal load
NT	Power supply
QRA...	Flame detector
QRC...	Blue-flame detector
	bl      blue
	br      brown
	sw      black
R	Control thermostat / pressurestat
RV	Gas regulation damper
SA	Actuator SQN...
SB	Safety limiter
STB	Safety limit thermostat
Si	External pre-fuse
t	Time
W	Limit thermostat / pressure switch
Z	Ignition transformer
ZV	Pilot gas valve
A	Start command (switching on by control thermostat or pressurestat (R))
B-B'	Interval for establishment of flame
C	Operating position of burner reached
C-D	Burner operation (generation of heat)
D	Controlled shutdown by control thermostat or pressurestat (R)
	<ul style="list-style-type: none"> <li>• Burner will immediately be shut down</li> <li>• Burner control will immediately be ready for new startup</li> </ul>
I	Cam I actuator
t1	Prepurge time
t1'	Purge time
t3	Preignition time
t3n	Postignition time
t4	Interval between ignition «Off» and release of fuel valve 2 (V2)
t10	Specified time for air pressure signal
t11	Programmed opening time for actuator (SA)
t12	Programmed closing time for actuator (SA)
t22	2 <sup>nd</sup> safety time
TSA	Ignition safety time
tw	Waiting time
	Control signal
	Required input signal
	Permissible input signal

# Dimensions

Dimensions in mm

LME...



Plug-in base AGK11... / AGK13...

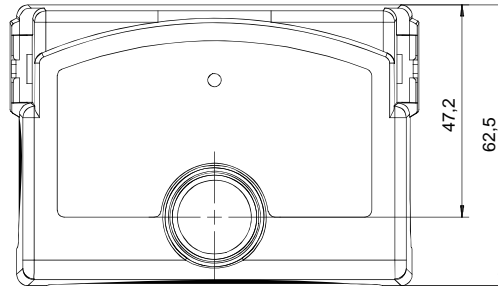
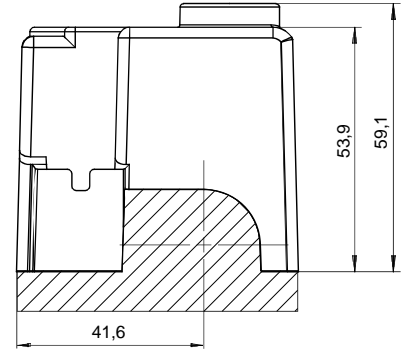
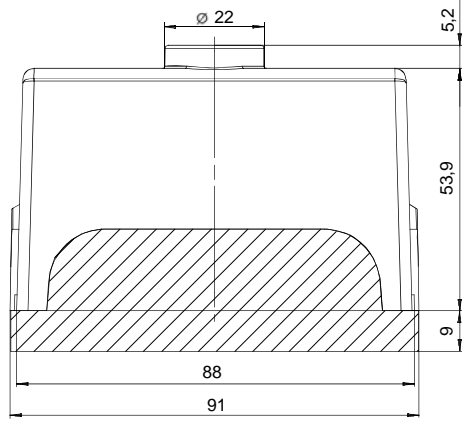

7101m02/0605

LME... with extension of lockout reset button AGK20...

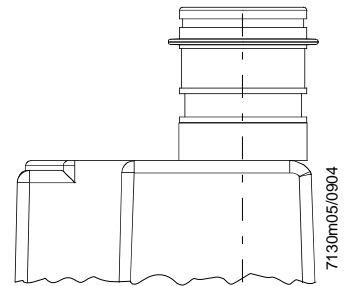
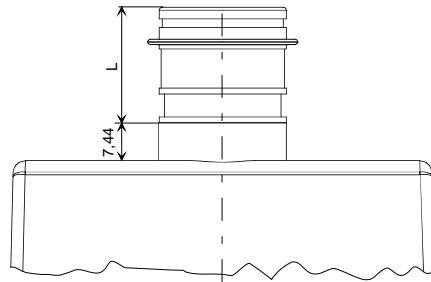

7130m05/0904

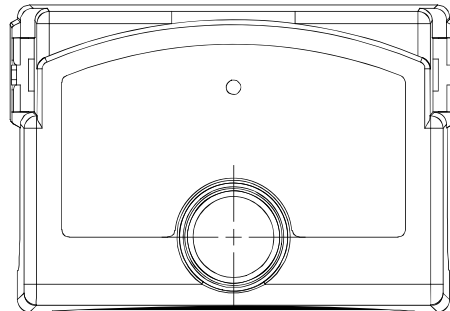

Product no.	Length «L» in mm
AGK20.19	19
AGK20.43	43
AGK20.55	55

Dimensions in mm

Ancillary unit  
AGQ3...A27

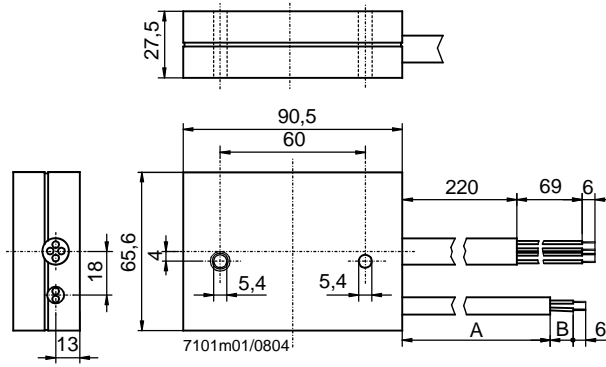

Product no.	Dimensions	
	A	B
AGQ3.1A27	500	19
AGQ3.2A27	300	34