



# COMPACT®

TRASFORMATORI PER BRUCIATORI E ZANZARIERE

Via Tiziano Vecellio, 14 31021 Mogliano Veneto (TV) Italy Tel +39 0415970120 Fax +39 0415970116  
C.F. / REG. Imprese di Treviso/ P.I. IT 01951700267 R.E.A. n° TV 180919 Capitale sociale €10.000 I.V.

## **F.I.D.A. S.r.l.: A BRIEF PRESENTATION**

F.I.D.A. S.r.l. produces high-tension ignition transformers from over 50 years. The main applications are: gas and oil burners, hydro cleaners and electric mosquito-killer. The whole range of our products is conforming to the European Low Tension directive (mark CE) and it is built according to the norm of product EN 61558. The models of wider diffusion are certified from VDE and UL.

Among the most important clients we can quote:

- BURNERS: Riello (I), Finterm SpA (Joannes) (I), Lamborghini SpA (I), Baltur SpA (I), MAN GmbH (D), Intecal GmbH (D), Electro-Oil GmbH (D), Giersch GmbH (D), Bentone AB (S)
- HYDROCLEANERS - GENERATORS: Alfred Kärcher GmbH (D), Portotecnica Div. Di IPC Spa (I), Comet SpA (I)
- MOSQUITO-KILLER: MO-EL (I), Electroinset (I), RST (P)

The F.I.D.A. transformers are very appreciated for their elevated reliability and for the advanced technology employed in their realization.

Thanks to the matured experience and the accurate laboratory searches, we have set an exclusive automatic method, on the basis of which the transformers, contained within special dice and places under high vacuum, contemporarily come impregnate and encapsulated with high isolation resin.

In this way we have succeeded in containing the ignition transformers in a unique insulating block, getting numerous and notable merits, as a very high electric isolation, safety and power of spark and greatest heat dissipation. Besides the COMPACT transformers include, incorporated in the insulating block, a magnetic screen for the reduction of the electromagnetic interferences.

F.I.D.A. is situated around 10 kms. far from Venice, in front of the "MOGLIANO VENETO" exit of the A27 highway.



# COMPACT®

TRASFORMATORI PER BRUCIATORI E ZANZARIERE

Via Tiziano Vecellio,14 31021 Mogliano Veneto (TV) Italy Tel +39 0415970120 Fax +39 0415970116  
C.F. / REG. Imprese di treviso/ P.I. IT 01951700267 R.E.A. n° TV 180919 Capitale sociale €10.000 I.V.

## INFORMAZIONI E AVVERTENZE

- CAVO DI ALIMENTAZIONE CON SPINA
- LUNGHEZZA CAVO STANDARD mm.450. ALTRE LUNGHEZZE A RICHIESTA
- SE IL CAVO DI ALIMENTAZIONE DEVE ESSERE SOSTITUITO, LA SOSTITUZIONE DEVE ESSERE ESEGUITA CON UN NUOVO CAVO DI ALIMENTAZIONE FIDA
- CAVI DI ALTA TENSIONE DISPONIBILI A RICHIESTA
- IL TRASFORMATORE DI ACCENSIONE DEVE ESSERE USATO CON UNITA' DI CONTROLLO
- SUL BRUCIATORE DEVE ESSERE MESSO IL SIMBOLO " ALTA TENSIONE ": UN TRIANGOLO GIALLO CON UN LAMPO NERO
- IL TRASFORMATORE DI ACCENSIONE E' PROTETTO DA POLVERE E UMIDITA', UTILIZZANDO CAVI AT FIDA CON GOMMININO
- CARETTERISTICHE DI TENSIONE DIVERSE, A RICHIESTA (120V , 60 Hz E ALTRE)

---

## AUSKÜNFTE UND WARNUNGEN

- STROMVERSORGUNGSKABEL MIT ANSCHLUßSTECKER
- STANDARD KABELSLÄNGE mm.450. VERSCHIEDENEN LÄNGEN AUF WUNSCH
- MUß DAS SPEISEKABEL ERNUERT WERDEN, MUß DIE ERNEUERUNG MIT EINEM NEUEN FIDA SPEISEKABEL GEMACHT WERDEN
- HOCHSPANNUNGSKABEL ZUR VERFÜGUNG AIF WUNSCH
- DER ZÜNDTRANSFORMATOR MUß MIT EINE KONTROLLEEINHEIT BENÜTZT WERDEN
- AM BRENNER MUß DER SYMBOL "HOCHSPANNUNG" GESTELLT WERDEN: EIN GELBE DREIECK MIT EINEM SCHWARZEN BLITZ
- GESCHÜTZT VOR STAUB UND FEUCHTIGKEIT, WENN MAN FIDA HOCHSPANNUNGSKABEL MIT DER SCHÜTZKAPPE BENUTZT WIRD.
- VERSCHIEDENEN SPANNUNGSMERKMALEN AUF WUNSCH (120V, 60 Hz u.s.w.)

---

## INFORMATIONS AND DIRECTIONS

- FEEDING CABLE WITH CONNECTOR
- STANDARD CABLE LENGTH mm.450. DIFFERENT LENGTHS ON DEMAND
- IF THE FEEDING CABLE HAS TO BE SUBSTITUTED, THE SUBSTITUTION MUST BE DONE WITH A NEW FIDA'S FEEDING CABLE
- HIGH TENSION CABLES AVAILABLE ON DEMAND
- THE IGNITION TRANSFORMER MUST BE USED WITH A CONTROL UNIT
- ON THE BURNER MUST BE PUT THE SYMBOL "HIGH VOLTAGE": A YELLOW TRIANGLE WITH A BLACK LIGHTNING
- THE IGNITION TRANSFORMER IS PROTECTED FROM DUST AND DAMP, USING FIDA'S CABLES WITH CAP.
- DIFFERENT TENSION CHARACTERISTICS ON DEMAND (120V, 60 Hz AND OTHERS)

# FIDA

31021 MOGLIANO (TREVISO) - ITALY -  
VIA TIZIANO, 14 - TEL. 041 / 5970120  
FAX 041 / 5970116

BUILT IN IGNITION TRANSFORMERS  
EINBAU ZÜNDTRANSFORMATOREN  
TRANSFORMATEURS D'ALLUMAGE A INCORPORER  
TRASFORMATORI D'ACCENSIONE DA INCORPORARE

## “COMPACT”®

DISEGNO DI PROPRIETA' DELLA FIDA CON DIVIETO DI DIVULGAZIONE  
E DI RIPRODUZIONE SALVO AUTORIZZAZIONE. LA FIDA SI RISERVA  
DI APPORTARE MODIFICHE SENZA PREAVVISO.

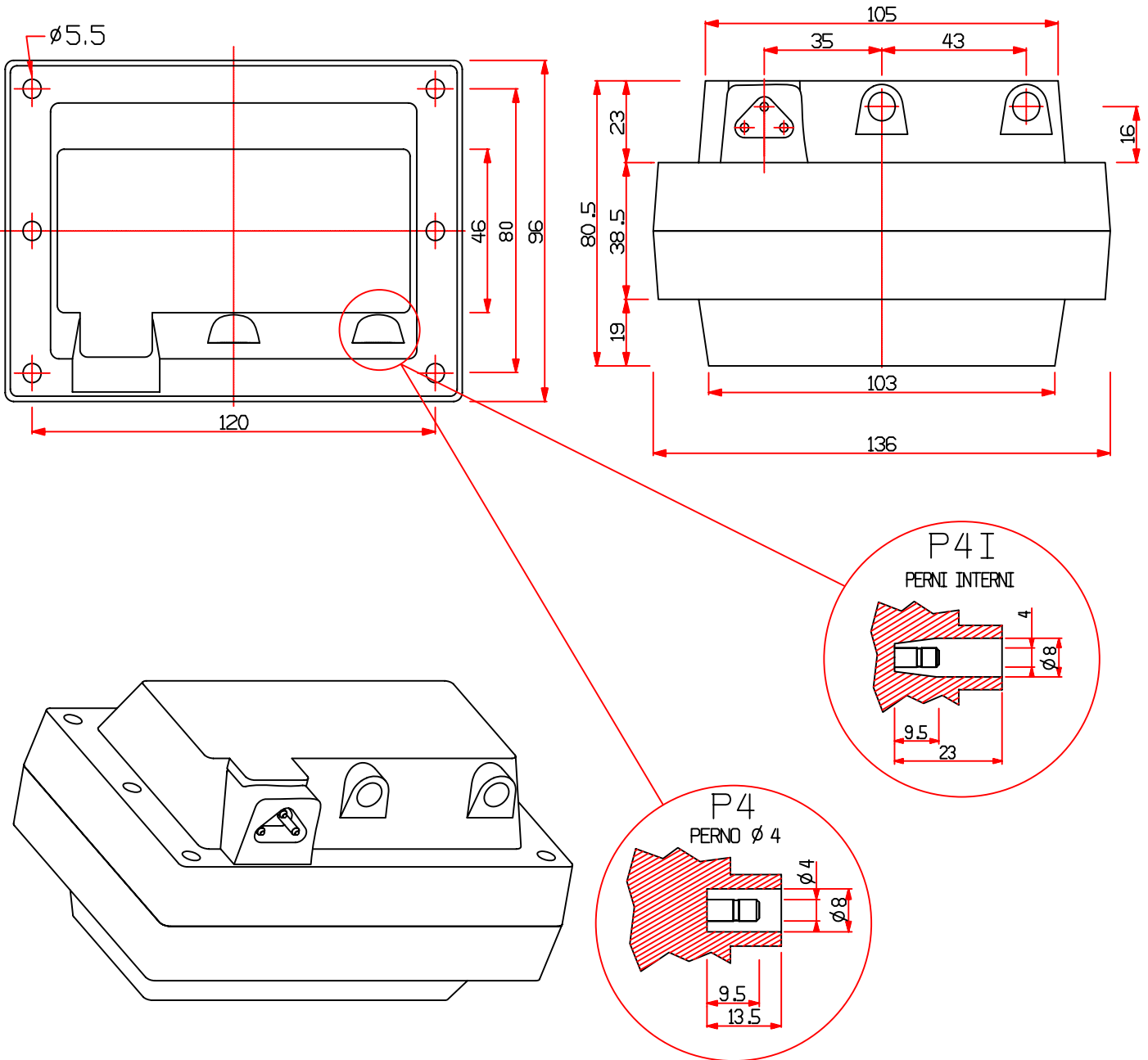

Ref.=G-S

Aggiornato il 01/03/10



# FIDA

31021 MOGLIANO (TREVISO) - ITALY -  
 VIA TIZIANO, 14 - TEL. 041 / 5970120  
 FAX 041 / 5970116

BUILT IN IGNITION TRANSFORMERS  
 EINBAU ZÜNDTRANSFORMATOREN  
 TRANSFORMATEURS D'ALLUMAGE A INCORPORER  
 TRASFORMATORI D'ACCENSIONE DA INCORPORARE

## “COMPACT”®

DISEGNO DI PROPRIETA' DELLA FIDA CON DIVIETO DI DIVULGAZIONE  
 E DI RIPRODUZIONE SALVO AUTORIZZAZIONE. LA FIDA SI RISERVA  
 DI APPORTARE MODIFICHE SENZA PREAVVISO.

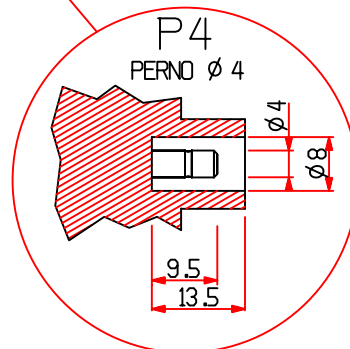
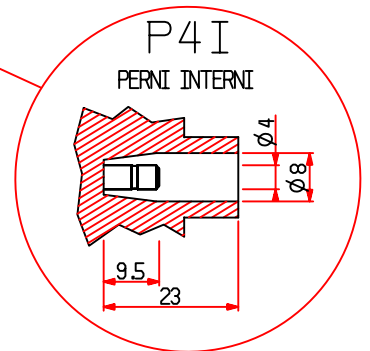
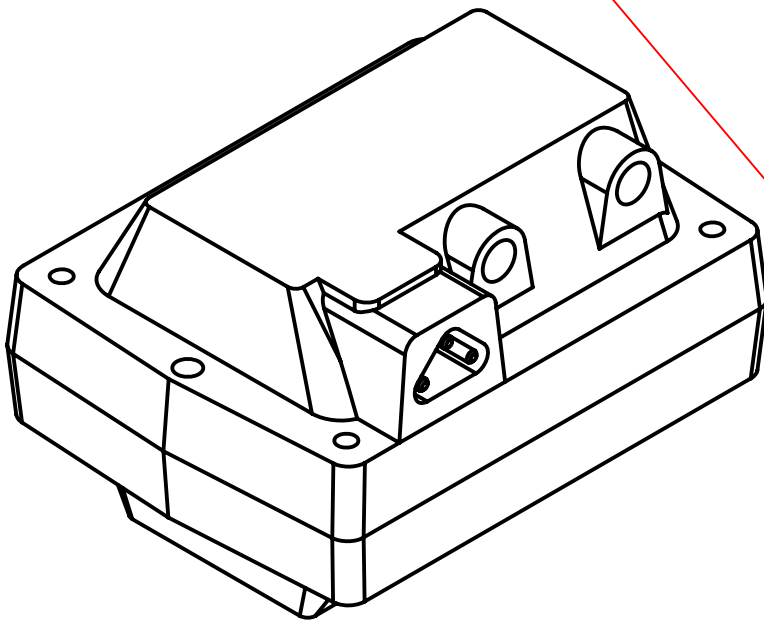
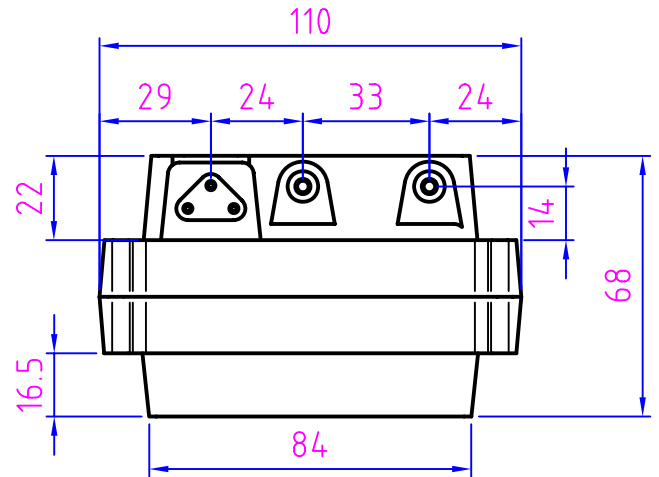
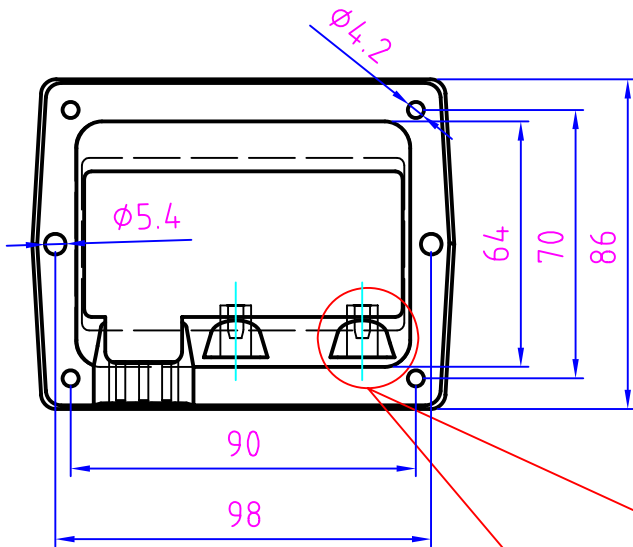

Ref.=M



I - 31021 MOGLIANO VENETO (Treviso) - ITALY  
Via Tiziano, 14 - S.P.Z.  
Phone: +39 (0)41 5970120 - Fax: +39 (0)41 5970116

BUILT IN IGNITION TRANSFORMERS  
EINBAU ZUENDTRANSFORMATOREN  
TRASFORMATEUR D'ALLUMAGE A INCORPORER  
TRASFORMATORI D'ACCENSIONE DA INCORPORARE

" COMPACT "

TYPE TYP TYPE TIPO	INTERMITTENCE EINSCHALTDAUER INTERMITTENCE INTERMITTENZA	STANDARD POWER SUPPLY STROMVERSORGUNG ALIMENTATION STANDARD ALIMENTAZIONE STANDARD			HIGH TENSION HOCHSPANNUNG HAUTE TENSION ALTA TENSIONE		MARKS ZEICHEN MARQUES MARCHI	
		V	Hz	A	V	mA		
8/10 CM	100%	230	50	0,5	2x4000	10	CE	
8/10 CM	100%	400	50	0,3	2x4000	10	CE	
5/18 PM	100%	230	50	0,5	1x5000	18	CE	CONFORMED TO EN 61558
6/20 PM	100%	120	60	1,15	1x6000	20	CE	
10/20 CM	25% su 3'	230	50	1,2	2x5000	20	CE	
8/20 CM	25% su 3'	230	50	1	2x4000	20	CE	
10/20 CM	33% su 3'	230	50	1,2	2x5000	20	CE	
12/20 CM	25% su 3'	230	50	1,4	2x6000	20	CE	CONFORMED TO EN 61558
10/30 CM	15% su 4'	230	50	1,45	2x5000	30	CE	CONFORMED TO EN 61558
10/30 CM	15% su 4'	120	60	2,7	2x5000	30	CE	
6/25 PM	25% su 3'	230	50	1	1x6000	25	CE	CONFORMED TO EN 61558
8/20 PM	25% su 3'	230	50	1	1x8000	20	CE	
8/20 PM	25% su 3'	120	60	1,6	1x8000	20	CE	
8/30 PM	25% su 3'	230	50	1,4	1x8000	30	CE	CONFORMED TO EN 61558

**REF.**  
M -P4  
M -P4I

**CM** MIDPOINT GROUND CENTRO A MASSA



**PM** ONE POLE GROUND POLO A MASSA

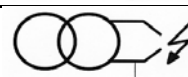

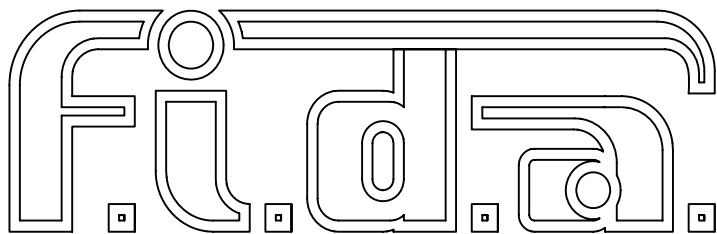

BUILT IN IGNITION TRANSFORMERS

EINBAU ZUENDTRANSFORMATOREN

TRANSFORMATEURS D'ALLUMAGE A INCORPORER

TRASFORMATORI D'ACCENSIONE DA INCORPORARE

“COMPACT”®

I - 31021 MOGLIANO VENETO (Treviso) - ITALY  
Via Tiziano, 14 - S.P.Z.  
Phone: +39 041 5970120 - Fax: +39 041 5970116



DISEGNO DI PROPRIETA' DELLA FIDA CON DIVIETO DI DIVULGAZIONE  
E DI RIPRODUZIONE SALVO AUTORIZZAZIONE. LA FIDA SI RISERVA  
DI APPORTARE MODIFICHE SENZA PREAVVISO.

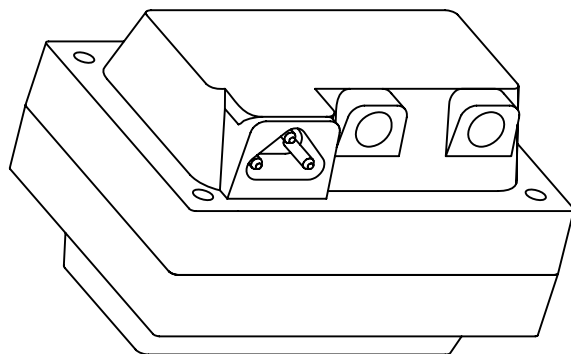
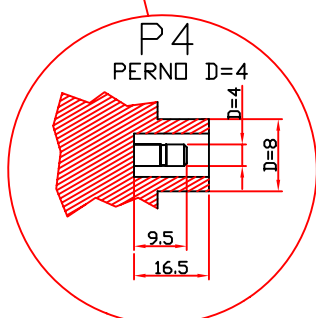
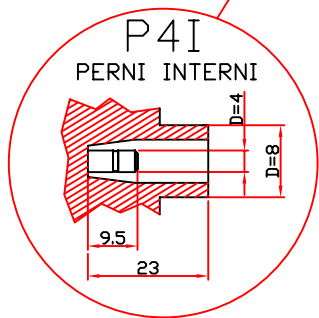
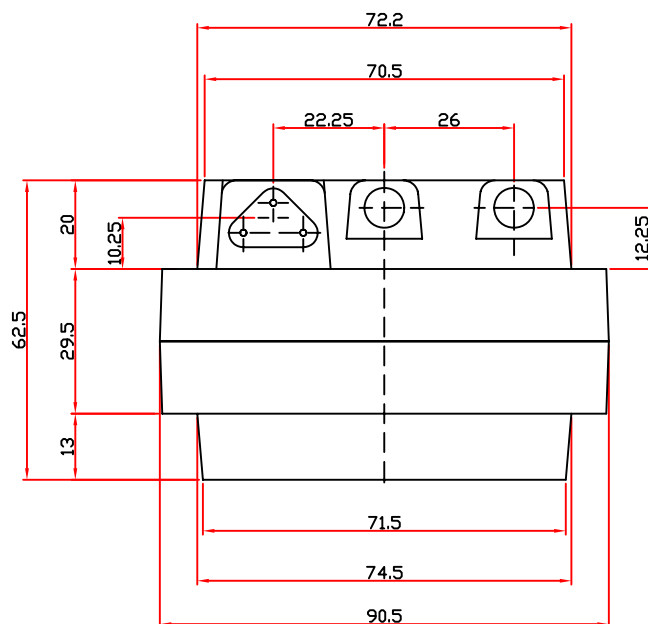
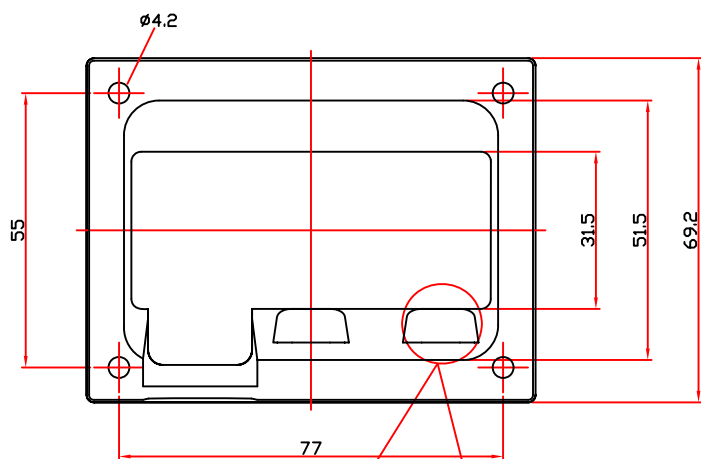

Ref.=P





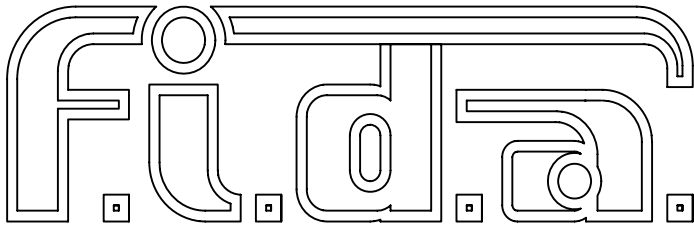

BUILT IN IGNITION TRANSFORMERS  
EINBAU ZUENDTRANSFORMATOREN  
TRANSFORMATEURS D'ALLUMAGE A INCORPORER  
TRASFORMATORI D'ACCENSIONE DA INCORPORARE

“COMPACT”®

I - 31021 MOGLIANO VENETO (Treviso) - ITALY  
Via Tiziano, 14 - S.P.Z.  
Phone: +39 041 5970120 - Fax: +39 041 5970116



DISEGNO DI PROPRIETA' DELLA FIDA CON DIVIETO DI DIVULGAZIONE  
E DI RIPRODUZIONE SALVO AUTORIZZAZIONE. LA FIDA SI RISERVA  
DI APPORTARE MODIFICHE SENZA PREAVVISO.

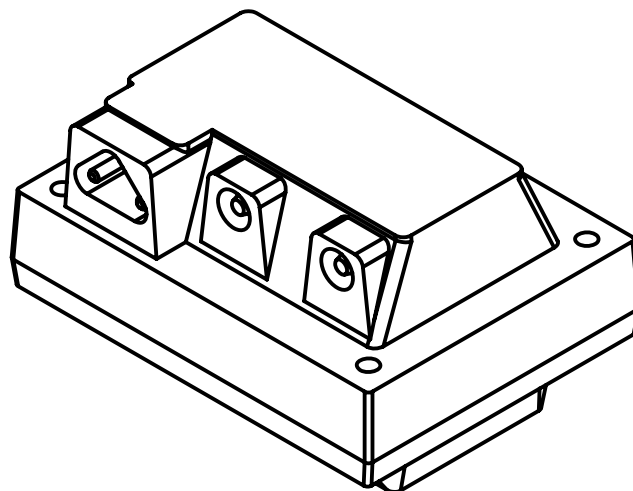
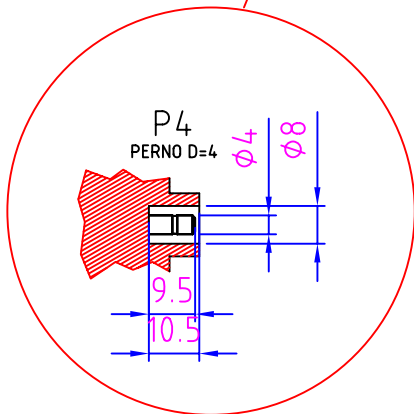
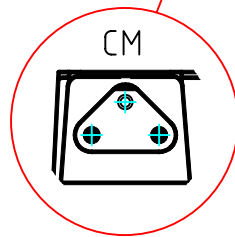
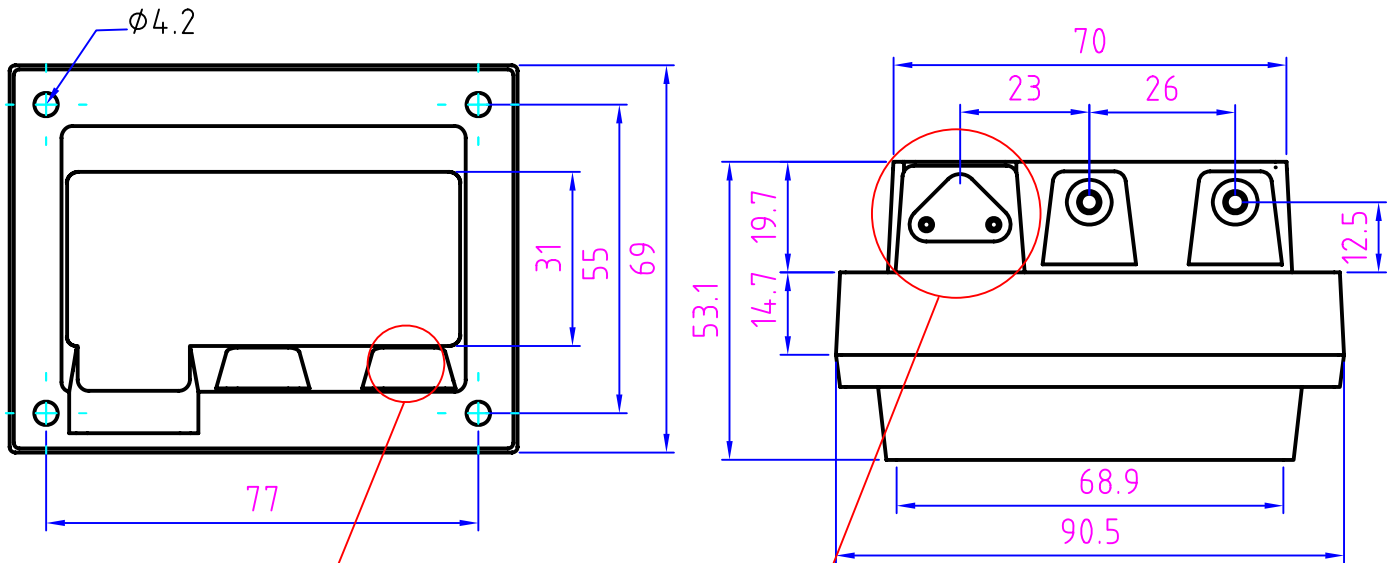

Ref.= PR

Aggiornato il 01/03/10



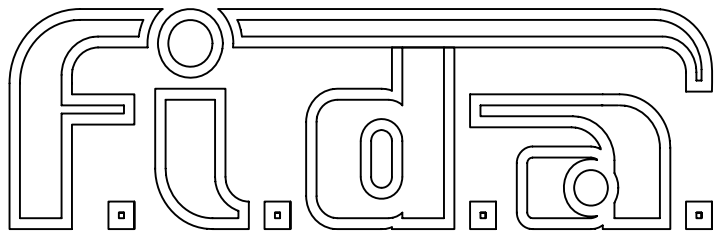

31021 MOGLIANO (TREVISO) - ITALY -  
VIA TIZIANO, 14 - TEL. 041 / 5970120  
FAX 041 / 5970116

BUILT IN IGNITION TRANSFORMERS  
EINBAU ZÜNDTRANSFORMATOREN  
TRANSFORMATEURS D'ALLUMAGE A INCORPORER  
TRASFORMATORI D'ACCENSIONE DA INCORPORARE

“COMPACT”®

DISEGNO DI PROPRIETA' DELLA FIDA CON DIVIETO DI DIVULGAZIONE  
E DI RIPRODUZIONE SALVO AUTORIZZAZIONE. LA FIDA SI RISERVA  
DI APPORTARE MODIFICHE SENZA PREAVVISO.

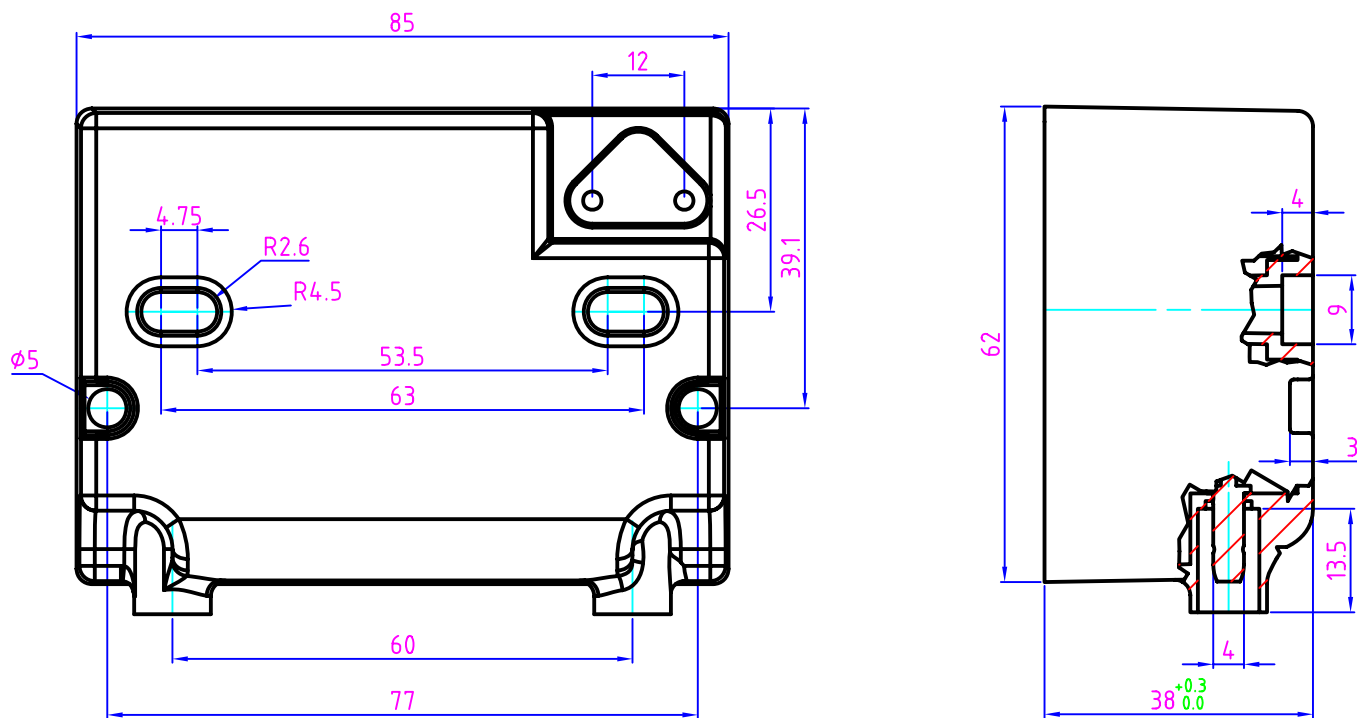

Electronic Transformer  
IS

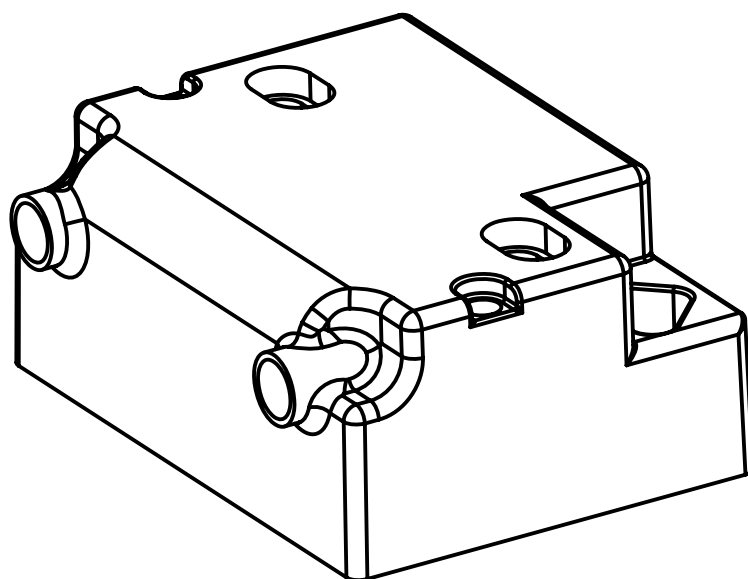

# FIDA

31021 MOGLIANO (TREVISO) - ITALY -  
VIA TIZIANO, 14 - TEL. 041 / 5970120  
FAX 041 / 5970116

BUILT IN IGNITION TRANSFORMERS

EINBAU ZÜNDTRANSFORMATOREN

TRANSFORMATEURS D'ALLUMAGE A INCORPORER

TRASFORMATORI D'ACCENSIONE DA INCORPORARE

## “COMPACT”®

DISEGNO DI PROPRIETA' DELLA FIDA CON DIVIETO DI DIVULGAZIONE  
E DI RIPRODUZIONE SALVO AUTORIZZAZIONE. LA FIDA SI RISERVA  
DI APPORTARE MODIFICHE SENZA PREAVVISO.

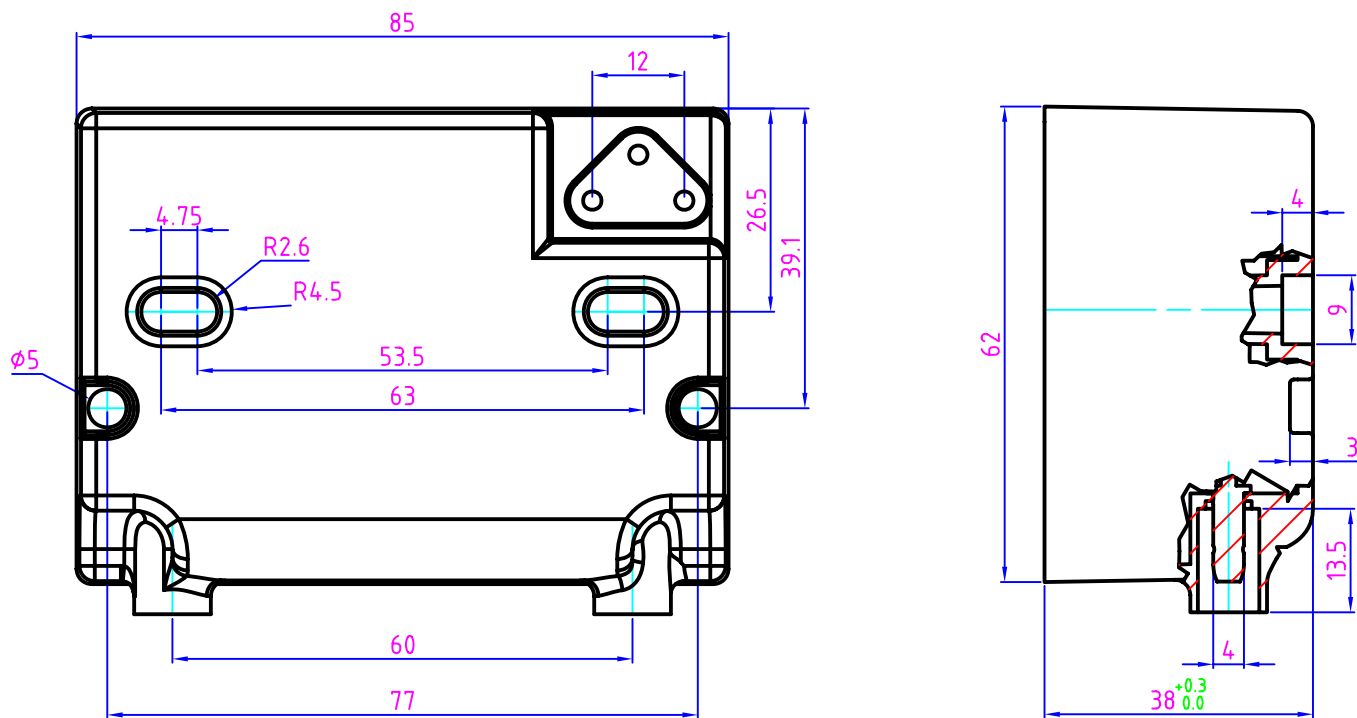

Electronic Transformer  
IT CM PM

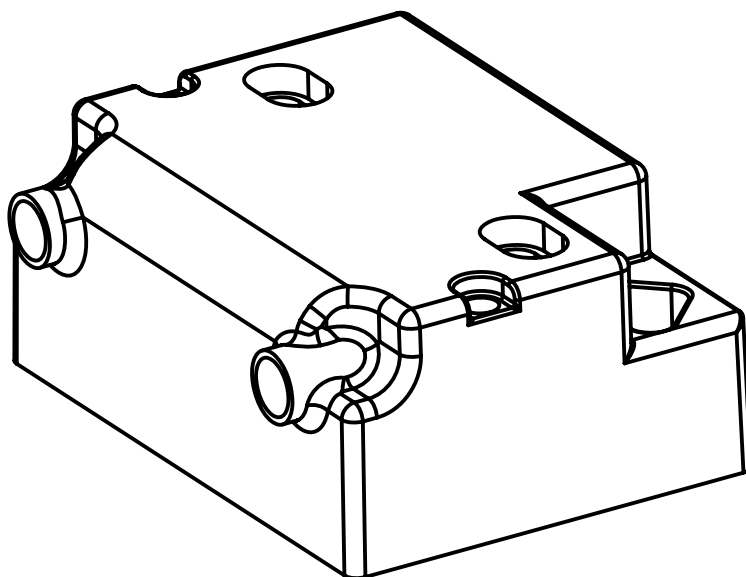

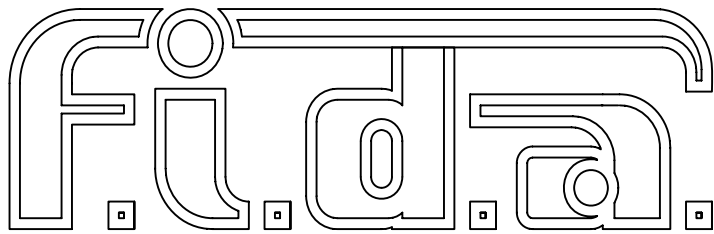

BUILT IN IGNITION TRANSFORMERS

EINBAU ZÜNDTRANSFORMATOREN

TRANSFORMATEURS D'ALLUMAGE A INCORPORER

TRASFORMATORI D'ACCENSIONE DA INCORPORARE

31021 MOGLIANO (TREVISO) - ITALY -  
VIA TIZIANO, 14 - TEL. 041 / 5970120  
FAX 041 / 5970116

“COMPACT”<sup>®</sup>

DISEGNO DI PROPRIETA' DELLA FIDA CON DIVIETO DI DIVULGAZIONE  
E DI RIPRODUZIONE SALVO AUTORIZZAZIONE. LA FIDA SI RISERVA  
DI APPORTARE MODIFICHE SENZA PREAVVISO.

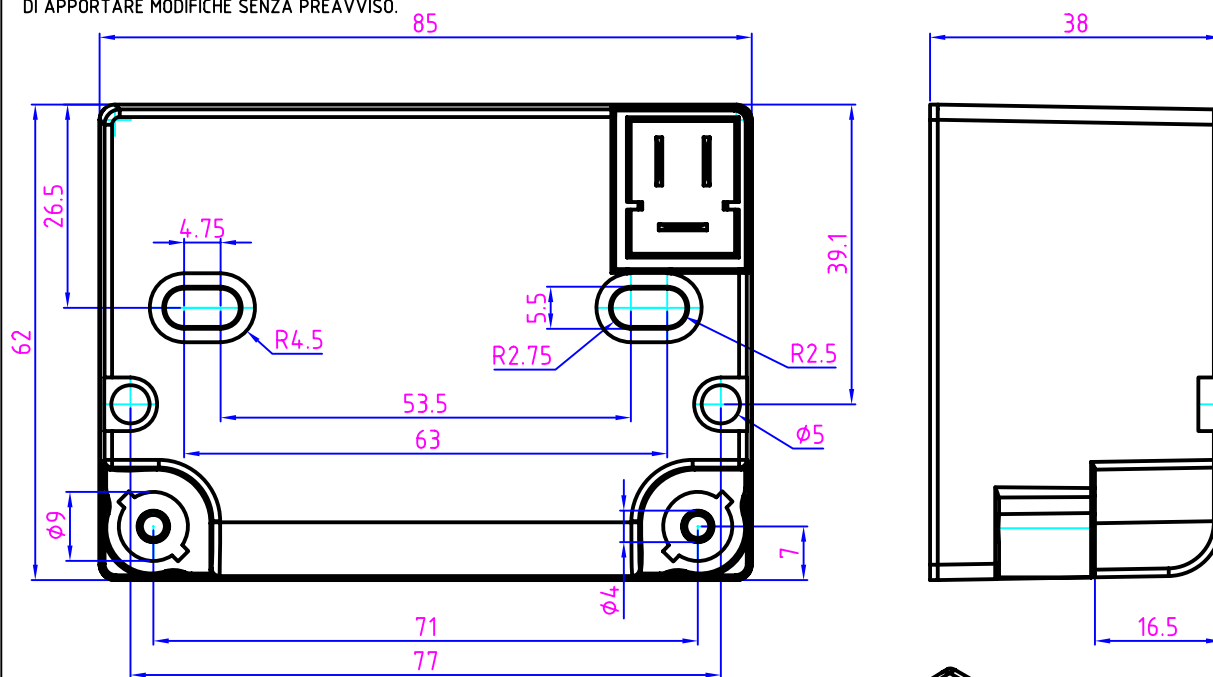

Electronic Transformer

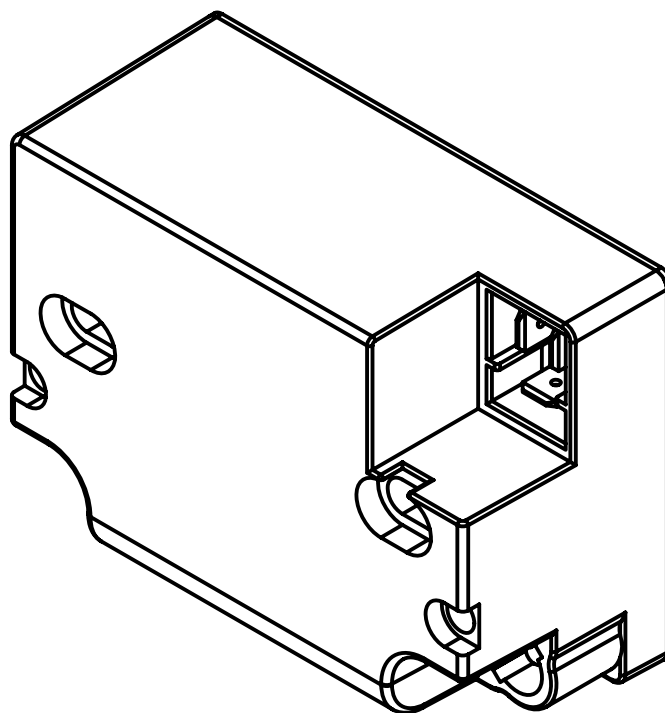





I - 31021 MOGLIANO VENETO (Treviso) - ITALY  
Via Tiziano, 14 - S.P.Z.  
Phone: +39 (0)41 5970120 - Fax: +39 (0)41 5970116

BUILT IN IGNITION TRANSFORMERS  
EINBAU ZUENDTRANSFORMATOREN  
TRASFORMATEUR D'ALLUMAGE A INCORPORER  
TRASFORMATORI D'ACCENSIONE DA INCORPORARE

## " COMPACT "

TYPE TYP TYPE TIPO	INTERMITTENCE EINSCHALTDAUER INTERMITTENCE INTERMITTENZA	STANDARD POWER SUPPLY STROMVERSORGUNG ALIMENTATION STANDARD ALIMENTAZIONE STANDARD			HIGH TENSION HOCHSPANNUNG HAUTE TENSION ALTA TENSIONE		MARKS ZEICHEN MARQUES MARCHI	
		V	Hz	A	V	mA		
26/30 IS	100%	230/240	50/60	0,15	1x26000	30	CE 	
26/30 CM	100%	230/240	50/60	0,15	2x13000	30	CE CONFORMED TO EN 61558	
26/30 PM	100%	230/240	50/60	0,15	1x26000	30	CE CONFORMED TO EN 61558	
26/30 IT	100%	230/240	50/60	0,15	1x26000	30	CE CONFORMED TO EN 61558	
26/35 IS	50% su 3'	230/240	50/60	0,25	1x26000	35	CE 	
26/35 CM	50% su 3'	230/240	50/60	0,25	2x13000	35	CE CONFORMED TO EN 61558	
26/35 IT	50% su 3'	230/240	50/60	0,25	1x26000	35	CE CONFORMED TO EN 61558	
26/48 IT	33% su 3'	230/240	50/60	0,35	1x26000	48	CE CONFORMED TO EN 61558	
26/40 PM	50% su 3'	230/240	50/60	0,25	1x26000	40	CE CONFORMED TO EN 61558	
24/26 IS	100%	200	50/60	0,2	1x24000	26	CE CONFORMED TO EN 61558	
26/30 IS	100%	200	50/60	0,22	1x26000	30	CE CONFORMED TO EN 61558	
26/30 PM	100%	115/120	50/60	0,35	1x26000	30	CE CONFORMED TO EN 61558	
26/30 IS	100%	115/120	50/60	0,35	1x26000	30	CE CONFORMED TO EN 61558	

**REF.**

ELECTRONIC TRANSFORMERS

**CM** MIDPOINT GROUND CENTRO A MASSA



**PM** ONE POLE GROUND POLO A MASSA

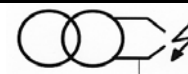

**IS** ISOLATO ISOLATED

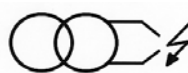

**IT** PRIMARIO CON COLLEGAMENTO DI MASSA PRIMARY WITH GROUND

