



Oil Burner Controls

LAE1...

Oil burner controls for use with burners of any capacity in intermittent operation. For safety reasons, at least one controlled shutdown must take place every 24 hours.

The LAE1... and this Data Sheet are intended for use by OEMs which integrate the burner controls in their products.

Use

The LAE1... with the associated silicon photocell detector RAR9... is used for the fully automatic startup and supervision of

- single-stage forced draft burners
- multistage forced draft burners
- modulating forced draft burners
- with any oil throughput

The design, control sequence and setting choices offered by the LAE1... enable this burner control to be used in almost any type and size of oil-fired combustion plant.

Use (cont'd)

Specific features

- Prepurge time adjustable between 8 and 63 seconds
- Operation with or without postpurge (optional)
- Fully automatic control of air damper, if required (with any actuator running time)
- Possibility of air check, in connection with a functional check of the air pressure switch prior to startup
- Ignition optional (directly ignition or with pilot burner)
- Preignition time adjustable («long» - during prepurge, «short» - 3 seconds)
- Safety time adjustable between 0 and 9 seconds
- Operation optional, without or with one-time start repetition in the event of loss of flame during operation
- Automatic extraneous light test during burner off periods and during the pre- and postpurge time
- Integrated lockout warning lamp
- Electric remote lockout reset
- Cover with 2 additional sealing screws to ensure protection against tampering (refer to «Dimensions»)

Warning notes



To avoid injury persons, damage to property or the environment, the following warning notes must be observed!

The unit may only be opened, interfered with or modified by qualified staff!

- All activities (mounting, installation and service work, etc.) must be performed by qualified staff
- Before making any wiring changes in the connection area, completely isolate the plant from mains supply (all-polar disconnection). Ensure that the plant cannot be inadvertently switched on again and that it is indeed dead. If not observed, there is a risk of electric shock hazard
- Ensure protection against electric shock hazard by providing adequate protection for the burner control's connection terminals
- Each time work has been carried out (mounting, installation, service work, etc.), check to ensure that wiring is in an orderly state and make the safety checks as described in «Commissioning notes»
- Press the lockout reset button only manually, without using any tools or pointed objects
- Fall or shock can adversely affect the safety functions. Such unit must not be put into operation, even if they do not exhibit any damage
- **Do not press the lockout reset button on the unit or the remote lockout reset button for more than 10 seconds since this would damage the lockout relay in the unit**

Mounting notes

- Ensure that the relevant national safety regulations are complied with
- Mount and adjust the flame detector such that it can detect the supervised flame

Installation notes

- Live and neutral conductors must not be mixed up
- For the connection of valves and other plant components, use the plant diagram and the mounting and commissioning instructions provided by the burner manufacturer
- In the event of loss of flame during operation, the burner control will initiate lockout. If start repetition is required, changeover latch «UL3» must be set to «Repetition»

Electrical connection of flame detectors

It is important to achieve practically disturbance- and loss-free signal transmission:

- Never run the detector cable together with other cables
 - Line capacitance reduces the magnitude of the flame signal
 - Use a separate cable
- Observe the maximum permissible detector cable lengths (refer to «Technical data»)

Commissioning notes

- When commissioning the plant or when doing maintenance work, make the following safety checks:

	Safety check to be carried out	Anticipated response
a)	Burner start with flame detector darkened	Lockout at the end of «TSA»
b)	Burner start with flame detector exposed to extraneous light	Lockout after no more than 40 seconds
c)	Burner operation with simulated loss of flame; for that purpose, darken the flame detector in operation and maintain that state	<ul style="list-style-type: none"> - With repetition: Restart followed by lockout at the end of «TSA» - Without repetition: Immediate lockout

Standards and certificates



Conformity to EEC directives

- Electromagnetic compatibility EMC (immunity) 2004/108/EC
- Low-voltage directive 2006/95/EC
- Directive for pressure devices 97/23/EC

Type			 Only with RAR...			 Only series 02
LAE1 / 1355	x	x	x	x	x	x
LAE1 / 8846	x	x	x	x	x	x
LAE1 / 8863	x	x	x	x	x	x
LAE1 / 8864	x	x	x	x	x	x
LAE1 / 8865	x	x	x	x	x	x



ISO 9001: 2000
Cert. 00739



ISO 14001: 2004
Cert. 38233

Life cycle

Burner controls has a designed lifetime* of 250,000 burner startup cycles which, under normal operating conditions in heating mode, correspond to approx. 10 years of usage (starting from the production date given on the type field). This lifetime is based on the endurance tests specified in standard EN230 and the table containing the relevant test documentation as published by the European Association of Component Manufacturers (Afecor) (www.afecor.org).

The designed lifetime is based on use of the burner controls according to the manufacturer's Data Sheet. After reaching the designed lifetime in terms of the number of burner startup cycles, or the respective time of usage, the burner control is to be replaced by authorized personnel.

* The designed lifetime is not the warranty time specified in the Terms of Delivery

Disposal notes



The unit contains electrical and electronic components and must not be disposed of together with household garbage.
Local and currently valid legislation must be observed.

Mechanical design

LAE1...

- Plug-in design
- The built-in unit fuse protects the control contacts against overloads
- Able for optional mounting position at burner, on control panes or in control cabinets
- Control unit driven by synchronous motor, the auxiliary relays, the electronic flame signal amplifier as soon as all the rest of switch, control and adjustable elements are build-on at stable PCBs and included in test circuit of burner control
- The burner control is secured to its base with 4 screws. The unit cover is protected against tampering by means of 2 sealing screws (refer to «Dimensions»)

Housing

- Large connection area
- Made of black, impact-proof and heat-resistant plastic
- Lockout reset button with viewing window, located behind it are
 - the lockout warning lamp
 - the lockout indicator
 - coupled to the program shaft
 - visible in the transparent lockout reset button
 - uses easy-to-remember symbols to indicate the type of fault and the point in time lockout occurred
- 4 extra terminals for the earth conductor, 4 extra terminals for the neutral conductor, and 4 auxiliary terminals
- to be keep by 4 screws of plug-in base

Type summary and ordering

Type reference / ordering *	Mains voltage	Factory settings			
		Hz	t1	TSA	t9
LAE1 / 1355	AC 220...240 V	50	30 s	5 s	5 s
LAE1 / 8846	AC 220...240 V	50	30 s	2 s	2 s
LAE1 / 8863	AC 100...110 V	50	30 s	2 s	2 s
LAE1 / 8864	AC 100...110 V	60	30 s	2 s	2 s
LAE1 / 8865	AC 220...240 V	60	30 s	2 s	2 s

* The type reference is given near the terminals inside the housing

Oil burner control without plug-in base refer to «Type reference»
Plug-in base not included in delivery, must be ordered as a separate item!

Accessories

Connection Accessories

- Plug-in base **AGG41041713 (AE)** with Pg11 thread for cable entry glands
- Plug-in base **AGG11.1** with M16 thread for cable entry glands

Silicon photocell detector RAR9... refer to Data Sheet N7713

Technical data

General unit data	Mains voltage	AC 220 V –15 %...AC 240 V +10 % AC 100 V –15 %...AC 110 V +10 %
	Mains frequency	50 Hz ±6 %
	Unit fuse (integrated)	T6.3H250V to DIN EN 60127
	Primary fuse (externally)	Max. 10 A (slow)
	Weight	Approx. 1.85 kg
	Power consumption	
	- On startup	Approx. 9 VA
	- In operation	Approx. 6 VA
	Mounting position	Optional
	Degree of protection	IP40, when built in, with the exception of the connection area (terminal base)
	Safety class	II
	Cable glands	Pg11 or BSP ¾"
	Perm. load on control outputs	
	- Per terminal	Max. 4 A to VDE 0660 AC3
	- Total (input current terminal 1)	Max. 5 A to VDE 0660 AC3
Environmental conditions	Storage	DIN EN 60721-3-1
	Climatic conditions	Class 1K3
	Mechanical conditions	Class 1M2
	Temperature range	-20...+60 °C
	Humidity	<95 % r.h.
	Transport	DIN EN 60721-3-2
	Climatic conditions	Class 2K2
	Mechanical conditions	Class 2M2
	Temperature range	-20...+60 °C
	Humidity	<95 % r.h.
	Operation	DIN EN 60721-3-3
	Climatic conditions	Class 3K5
	Mechanical conditions	Class 3M2
	Temperature range	-20...+60 °C
	Humidity	<95 % r.h.



Condensation, formation of ice and ingress of water are not permitted!

Flame detectors

Refer to Data Sheet N7713!

Perm. length of connecting cable 20 m
(in the case of longer distances, use low-capacitance cable, e.g. single-core, and RAR9...)

Required detector current Min. 8 µA
Possible detector current Max. 25 µA

Measurement circuit for LAE1...

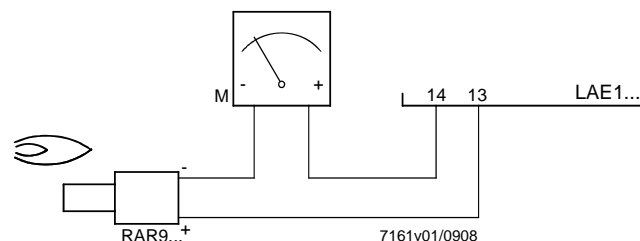

Legend
RAR9... Silicon photocell detector
M Microammeter

Function

Preconditions for burner startup

- The burner will be started only if
- the sequence switch of the LAE1... is in its start position
 - the LAE1... has not triggered lockout
 - the contacts of all control and monitoring devices in the control loop between terminals 8 and 9 are closed
 - the air pressure switch – if included in the test circuit – does not signal air pressure

Faults in the flame supervision section of the LAE1... prevent startup or, in the case of startup, lead to lockout.



If the air damper is not controlled by the LAE1..., terminals 20, 21 and 22 must be interconnected.

The LAE1... can control the following burner plant components:

- Fan motor
- Flue gas fan
- Air damper
- Ignition transformer
- 1 to 3 fuel valves
- 1 external fault indication unit

A load controller with 3-position output can be connected.

Startup sequence

Specific features

- Continuous indication of the program sequence in the viewing window of the unit cover
- In the event of fault, the program indicator shows the program phase during which lockout occurred
- The motor of the sequence switch can be switched off to facilitate the burner setting procedure
- The cam shaft can be rotated manually

... on startup

First, the fan motor is switched on via terminal 3 and the actuator is controlled via terminal 22. When the air damper reaches its maximum position, the sequence switch of the LAE1... starts to operate and the prepurge time commences. The minimum air pressure set on the air pressure switch must then be reached within 10 seconds (or within 7 seconds in the case of operation with postpurge) and be maintained until controlled shutdown occurs. Otherwise, the burner control will initiate lockout. A flame signal during the prepurge time also leads to lockout. On completion of the adjusted prepurge time, the air damper is given the control command to return to the minimum position. During the time the damper is closed, the sequence switch does not operate.

As soon as the signal contact for the minimum throttling setting is actuated by the actuator, the sequence switch starts again and controls the program sequence which can no longer be influenced from outside:

- Preignition (if the ignition equipment was not already switched on during the prepurge time)
- Release of the first oil valve connected to terminal 5 (the fuel valve of a pilot burner which, on completion of the second safety time must be switched off, is to be connected to terminal 10, however)
- Completion of the adjusted safety time. If, during this period of time, no flame is established, the burner control will initiate lockout with interlocking
- 11 seconds after release of the first oil valve, the second oil valve will be released
- The pilot burner – if present and connected to terminal 10 – will be shut down
- The load controller will be switched on after another interval of 12 seconds, which means that the burner's operating position is now reached. From now on, the load controller controls burner output by increasing or decreasing the oil throughput and the amount of air, depending on the demand for heat

If the flame is lost during operation, the burner control will initiate lockout or – if operating mode «with start repetition» is used – make a new start.

In that case, the sequence switch must return to its start position, however, and post-purging will take place – if programmed.

Control sequence

... after a controlled shutdown

Controlled shutdown occurs as soon as a control or monitoring device in the control loop between terminals 8 and 9 opens its contact.

The fuel valves are immediately shut and postpurging, if included, will start.

The sequence switch will return to its start position where it stays until the next switch on command is given.

... after lockout of the LAE1...

After pressing the integrated or external lockout reset button, the sequence switch will return to its start position, provided the fault has been corrected.

The only component of the burner plant that is switched on here is the fan motor connected to terminal 17.

Since in normal circumstances, the control thermostat or pressurestat continues to call for heat, the sequence switch initiates a new start after it has reached its start position.

Program sequence indicator

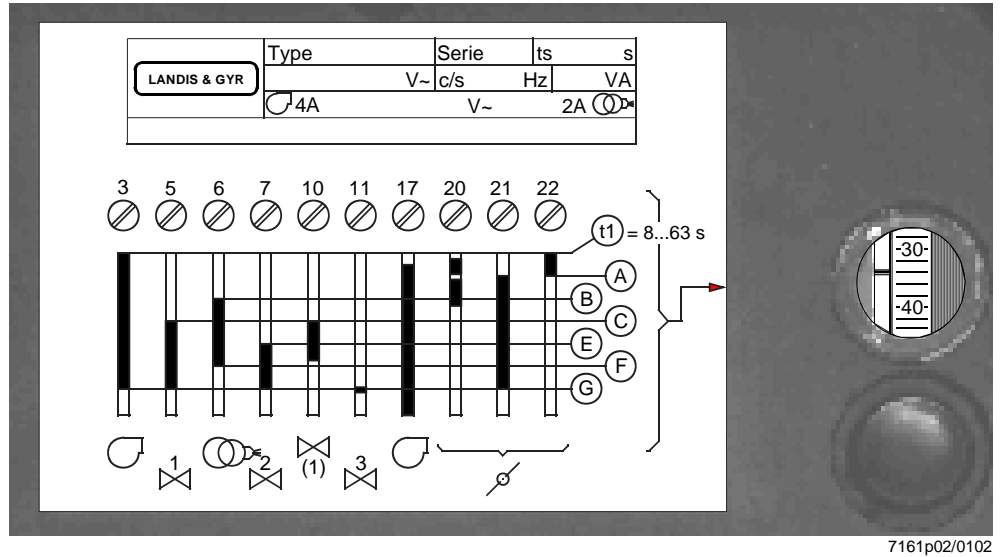

The program sequence indicator shows the respective startup position. The **letters** correspond to those given in the sequence switch diagram beside the viewing window. The **numbers** give the remaining prepurge time. In the event of lockout, the sequence switch and the program sequence indicator stop, thus indicating the operating phase during which lockout occurred.

Reading the program sequence indicator

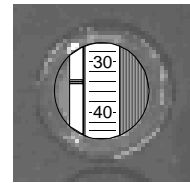
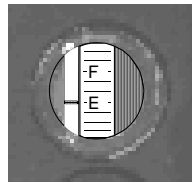

Valve 2 connected to terminal 7 will be opened

Pre-purge time lasts another 35 seconds

Changing the control sequence

Two changeover latches on the underside of the burner control can be used to make the following settings:

UL2	Long preignition time	During prepurging	Factory setting
	Short preignition time	3 seconds	---
UL3	With repetition	In the event of loss of flame during operation	---
	Without repetition	In the event of loss of flame during operation	Factory setting



The factory setting can only be changed after loosening the screw. Retighten screw properly!

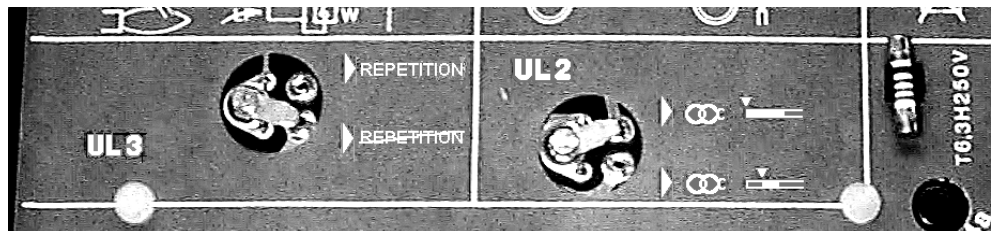

Settings and adjustments on the burner control

- Loosen all 6 screws and remove the cover of the LAE1...
- Always start counting the switching cams from the motor side
- You can manually turn the cam shaft to any position you want (clockwise rotation as seen from the motor)

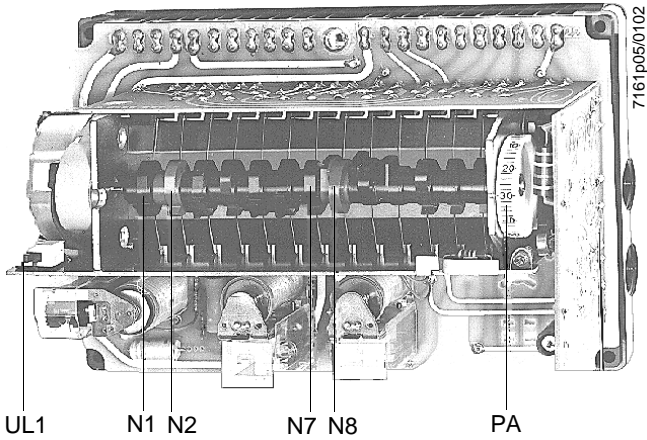

Setting elements

- N1 Cam 1, fixed
- N2 Cam 2, adjustable (safety time)
- N3 Cam 3, adjustable (safety time)
- N7 Cam 7, fixed
- N8 Cam 8, adjustable (prepurge time)
- PA Sequence position indicator
- UL1 Operating switch ON / OFF for sequence switch motor

On the underside of the base:

- UL2 Changeover latch «short / long» preignition time
- UL3 Changeover latch «with / without» repetition

Adjusting the prepurge time «t1»

- Loosen the fixing screw of the red cam «N8»
- Turn cam shaft manually until the required prepurge time is indicated next to the index notch on the sequence switch carrier
- Hold the cam shaft firm and turn cam «N8» until the tappet operated by it trips, or until the cam stops at this tappet
- Tighten the cam's fixing screw **carefully** and then check the adjusted time.
The adjusted time is also visible through the viewing window when the LAE1... is in its start position

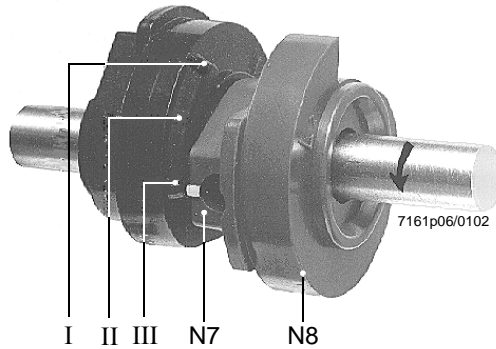

Adjustment of the mark of the red cam «N8» to the graduation marks of the black cam «N7» results in the prepurge times given in the adjacent table.

Adjustment to	t1
Graduation mark I	8 s
Graduation mark II	18 s
Graduation mark III	28 s
At stop	63 s
Factory setting	approx. 30 s

Adjusting the safety time «TSA»

- Loosen the stop screws of cams «N2» and «N3»
- Hold cam N1 firm and align the graduation mark of cam «N2» to the corresponding time marking of cam N1 (intermediate positions possible) (see adjacent illustration and table). Lock cam «N2»
- Set adjustment mark of cam «N3» to the lowest stop of cam «N2» and lock cam «N3»
- Check the adjusted safety time and adjust the new value on the rating plate of the cover (adjustment slot on the underside of the cover)

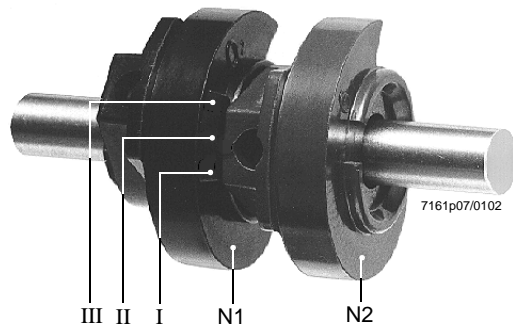

Adjustment to	TSA
Graduation mark I	0 s
Graduation mark II	4.5 s
Graduation mark III	9 s
Factory setting	≤ 5 s

Connection diagram

Unit fuse 6.3 A (slow) in the current path between terminal 1 and relay contact «br...» is not shown.

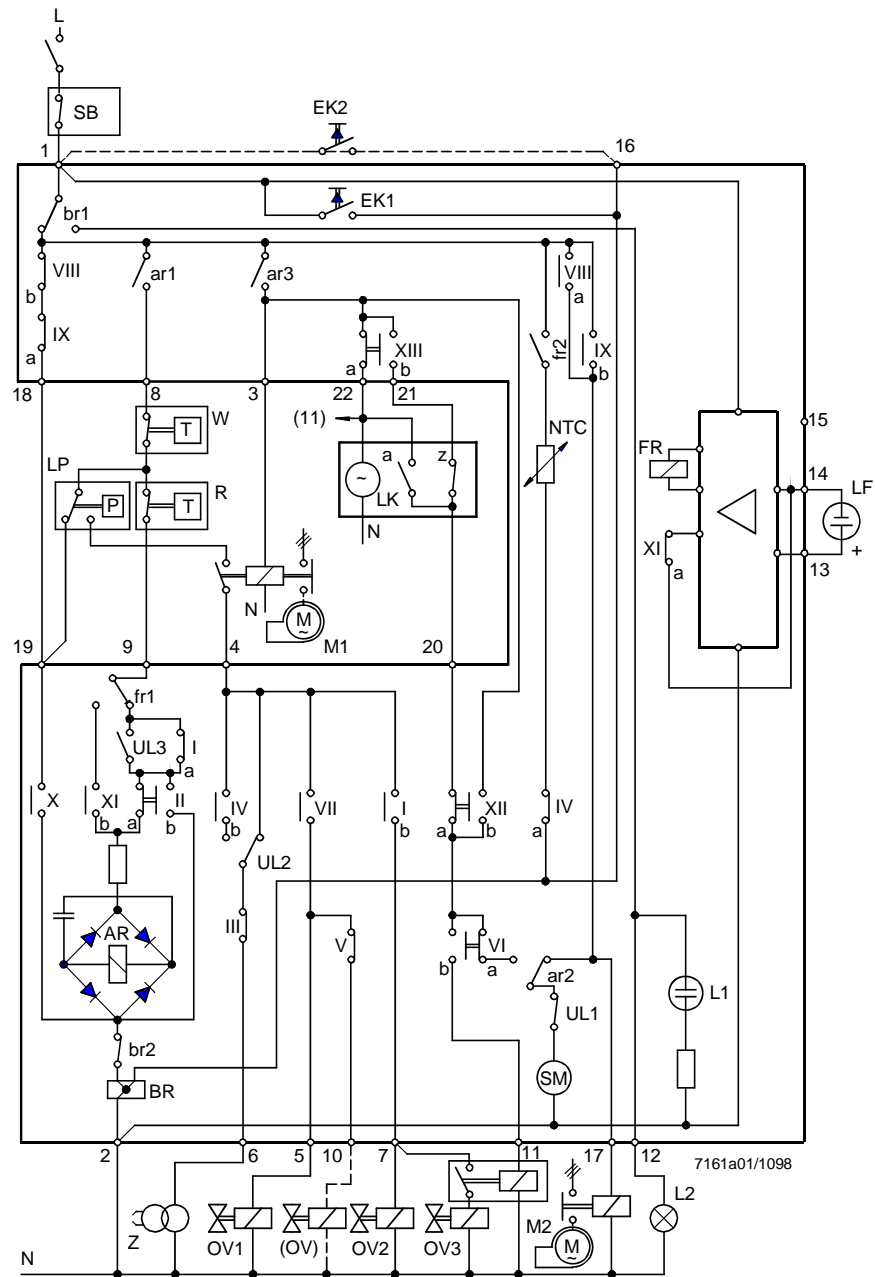

Legend

AR	Load relay with contacts «ar...»	LP	Air pressure switch
BR	Lockout relay with contacts «br...»	M...	Fan, ventilator
EK1	Lockout reset button on the LAE1... (do not press «EK1» for more than 10 seconds!)	NTC	High temperature conductor (delay device)
EK2	Remote lockout reset button (do not press «EK2» for more than 10 seconds!)	OV...	Oil valve
FR	Flame relay with contacts «fr...»	(OV)	Fuel valve for a pilot burner, will be switched off on completion of the 2 nd safety time
L1	Fault indication lamp (integrated)	R	Control thermostat or pressurestat
L2	Fault indication lamp (external)	SB	Safety limit thermostat
LF	Light detector (silicon photocell detector RAR9...)	SM	Synchronous motor of sequence switch
LK	Actuator with end or auxiliary switches a = actuator travels to the «fully open» position (max. air volume) z = actuator travels to the «fully closed» position (min. air volume)	UL1	Operating switch for sequence switch motor (only accessible when cover is removed)
		UL2	Changeover latch «Long / short preignition time»
		UL3	Changeover latch «With / without repetition»
		W	Limit thermostat or pressure switch
		Z	Ignition transformer

Time diagram of sequence switch

The maximum permissible afterburn time is 7 seconds – from the start of «t6».
Customer-specific presettings of the times on request!

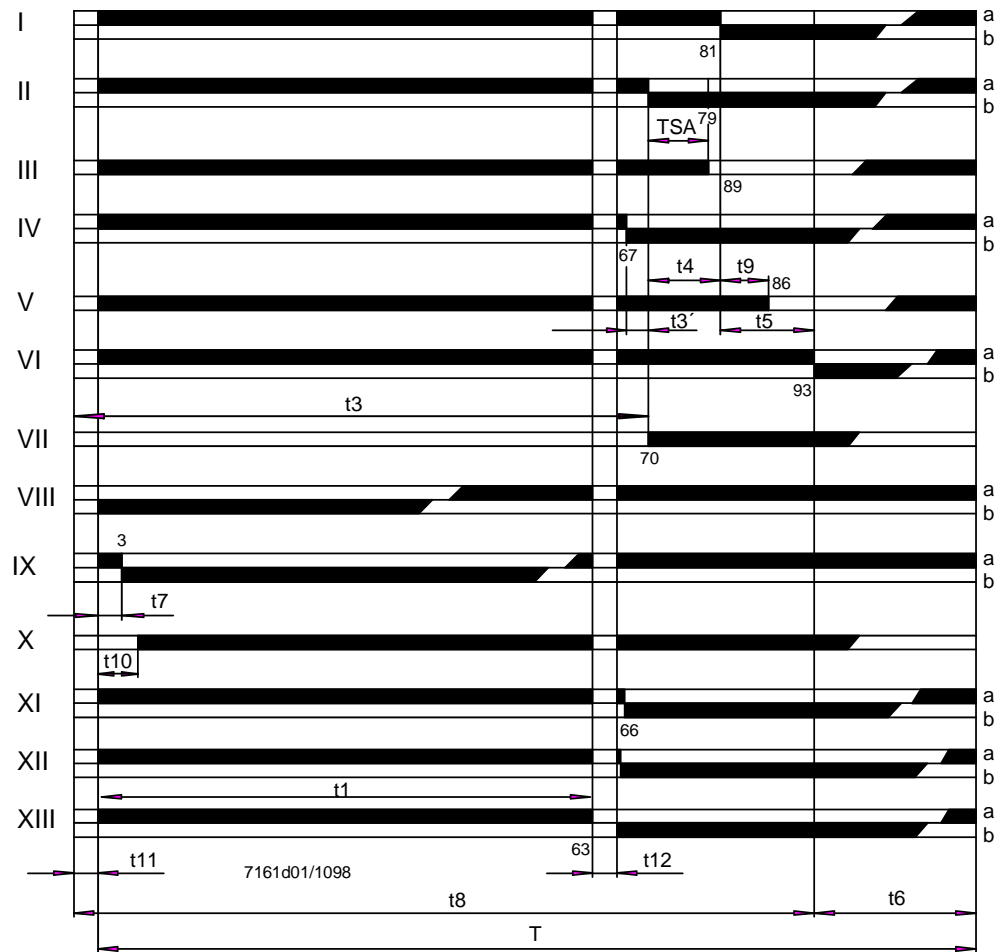

Legend

T	120 s	Cycle time of the sequence switch
TSA	0...9 s	Adjustable first safety time
t1	8...63 s	Adjustable prepurge time
t3	$t1 + t11 + t12 + 7$ s	«Long» preignition time
t3'	3 s	«Short» preignition time
t4	11 s	Interval between release of 1 st and 2 nd fuel valve
t5	12 s	Interval between release of 2 nd and 3 rd fuel valve or load controller
t6	$T - (30 + t1)$	Postpurge time
t7	3 s	Delay time
t8	$t1 + 30 + t11 + t12$	Total startup time
t9	5 s	Second safety time (only when ignition with pilot burner)
t10	10 s	Bridging time (predefined time for air control)
t11	optional	Opening time for the air damper
t12	optional	Closing time for the air damper

Connection examples

Connection diagram and sequence program for operation with long preignition and repetition (actuator control checked, no load control).

* When using an air pressure switch «LP», the connections between terminals 3 and 4 and 8 and 18 are not required

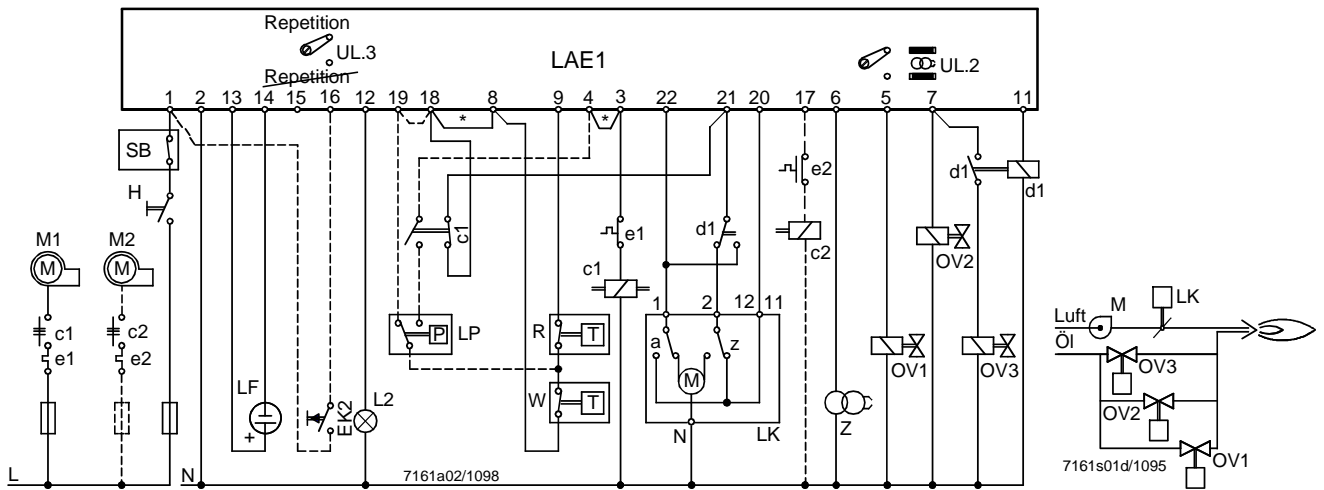

Air damper control (in detail)

In the case of burners without or with air damper not controlled by the LAE1..., terminals 20, 21 and 22 must be interconnected.

In that case, current path 18-c1-21 must not be present!

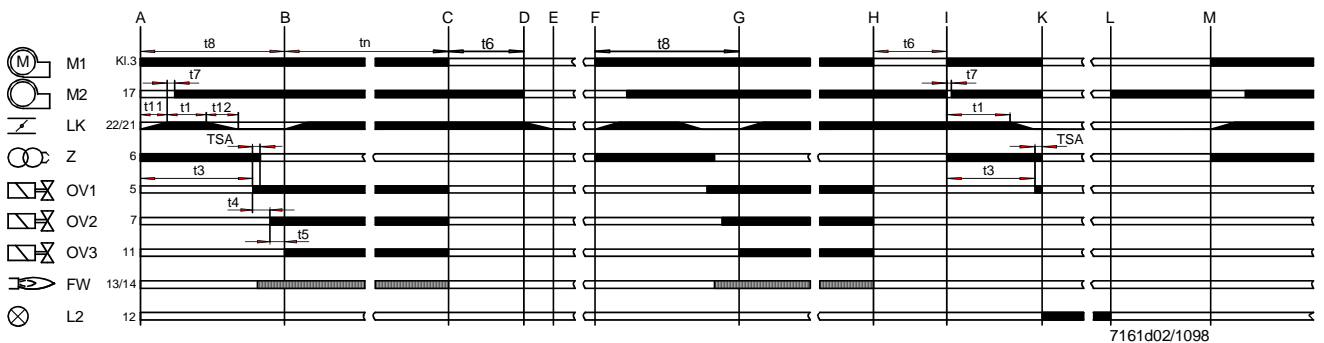
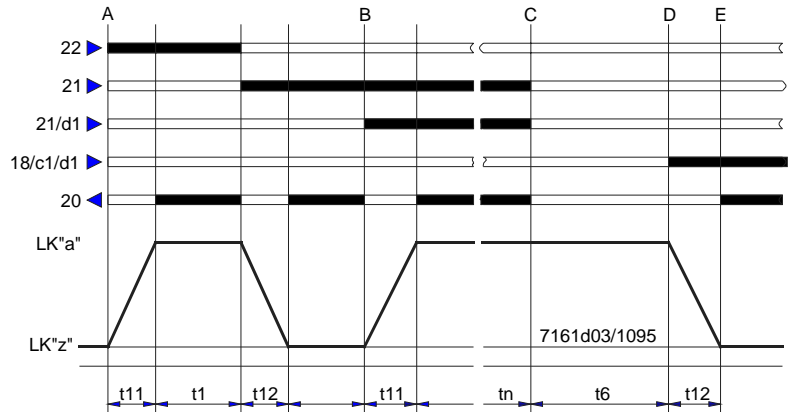

Legend

A	Start	G-H	Operation
A-B	Normal startup	H	Loss of flame
B-C	Operation	H-I	Return to start position
C	Controlled shutdown	I	Repetition
C-D	Postpurging	I-K	Startup without establishment of flame
D-E	Closing the air damper	L	Fault
E-F	Burner off period	L-M	Return to start position
F	Restart	M	Restart
F-G	Startup		

Connection examples (cont'd)

Connection diagram and sequence program for operation with short preignition and without repetition.
 Ignition of main burner with light oil pilot burner (on / off control with checked actuator control).

* When using an air pressure switch LP, the connections between terminals 3 and 4 and 8 and 18 are not required

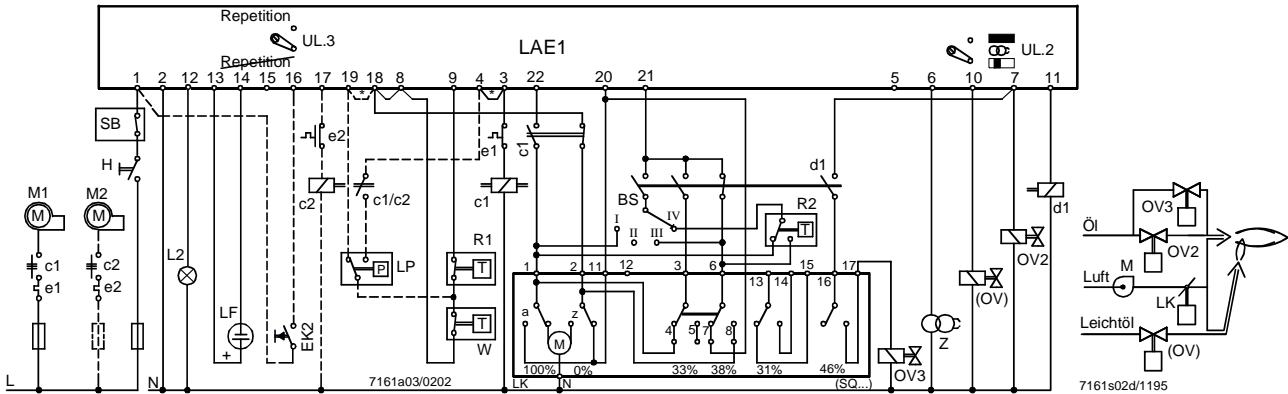

Control switch «BS»

- I Nominal load
- II Stop
- III Low-fire load
- IV Automatic control

Air damper control (in detail) →

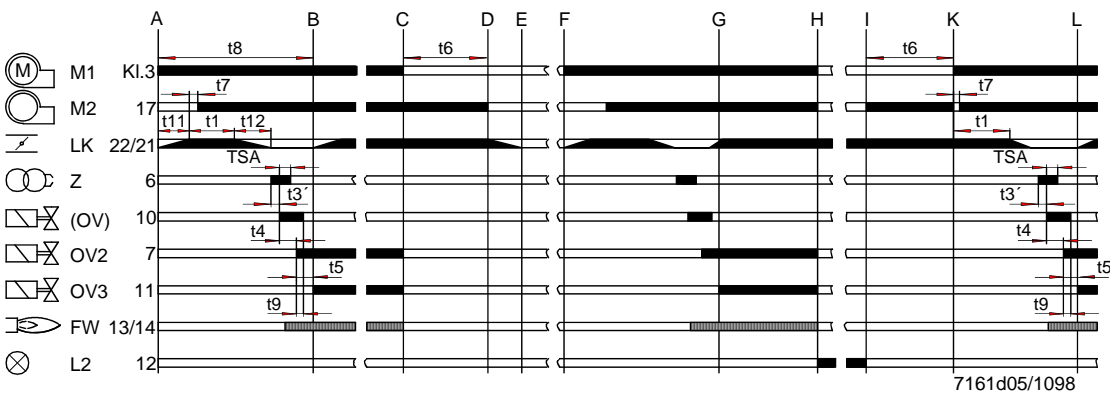
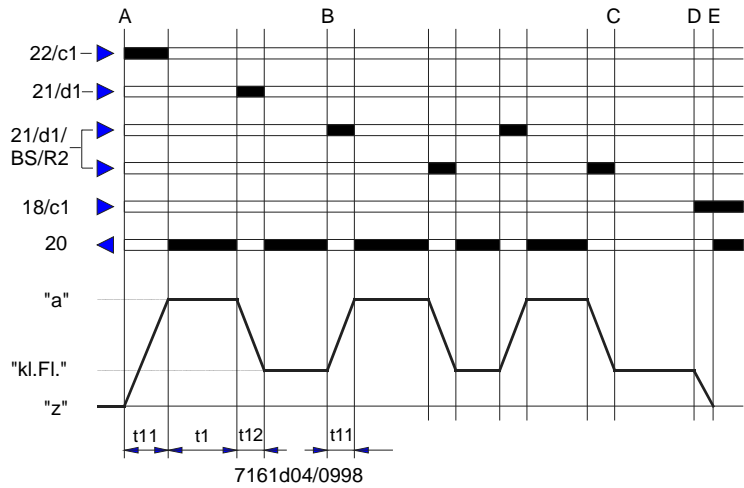

Legend

- | | |
|----------------------------|------------------------------|
| A Start | G-H Operation |
| A-B Normal startup | H Loss of flame |
| B-C Operation | H-I Fault |
| C Controlled shutdown | I Reset |
| C-D Postpurging | I-K Return to start position |
| D-E Closing the air damper | K Restart |
| E-F Burner off period | K-L Startup |
| F Restart | L Operation |
| F-G Startup | |

Connection examples (cont'd)

Connection diagram for modulating burner control with checked actuator control.

Burners designed for modulating burner control also use the devices of the temperature or pressure control loop, in addition to the standard burner control equipment.

Example:

- One modulating controller with a 3-position output
 - Temperature or pressure sensor
 - One actuator for the control of the air damper and oil throughput ratio control
 - One auxiliary relay
 - One operation mode switch
 - One oil volume controller
- QA... / QB...
SQ...
d1
BS
RV

* When using an air pressure switch LP, the connections between terminals 3 and 4 and 8 and 18 are not required

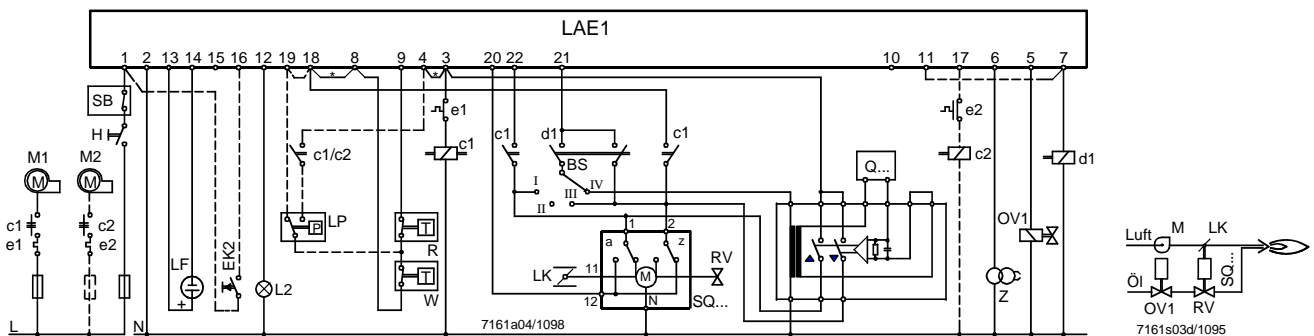

Control of semiautomatic operating mode

This circuit is used when, for specific reasons, fully automatic operation is not desired.

Example: Industrial burners

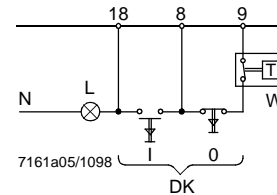

The burner is started by pressing button I (N.O.). Burner shutdown is achieved either by pressing button 0 (N.C.) or when there is a response from the limit thermostat.

Air pressure switch LP

(Recommended for burners that use separate motors for the fan and the fuel pump).

The air pressure is continuously monitored from burner startup through controlled shutdown.

If 10 seconds after the start of prepurging, or 7 seconds with the program with pre- and postpurging, the adjusted and required minimum air pressure is not reached, or if the air pressure drops again, the burner control will initiate lockout.

If air pressure switch LP is connected as shown in the adjacent diagram, an automatic functional check is made prior to each start.

If the contact position is wrong, there will be no start.

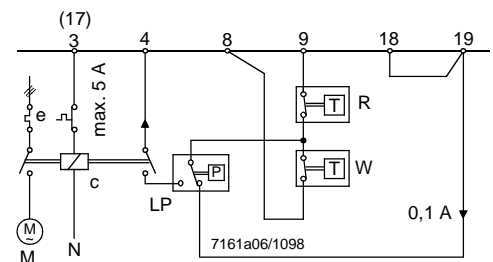

Legend

AR	Load relay with contacts «ar...»
BR	Lockout relay with contacts «br...»
BS	Operation switch
c...	Fan contactor with contacts «c...»
d...	Auxiliary relay with contacts «d...»
DK	Push-button
e...	Thermal overcurrent release
EK1	Lockout reset button on the LAE1... (do not press «EK1» for more than 10 s!)
EK2	Remote lockout reset button (do not press «EK2» for more than 10 s!)
FR	Flame relay with contacts «fr...»
FW	Flame supervision
H	Main switch
L	Lamp
L1	Fault indication lamp (integrated)
L2	Fault indication lamp (external)
LF	Light detector (silicon photocell detector RAR9...)
LK	Actuator with end or auxiliary switches a = actuator travels to the «fully open» position (max. air volume) z = actuator travels to the «fully closed» position (min. air volume)
LP	Air pressure switch
M...	Fan, ventilator
NTC	High temperature conductor (delay device)
OV...	Oil valve
(OV)	Fuel valve for a pilot burner, will be switched off on completion of the second safety time
R	Control thermostat or pressurestat
RV	Control valve
SB	Safety limit thermostat
SM	Synchronous motor of sequence switch
UL1	Operating switch for sequence switch motor (only accessible when cover is removed)
UL2	Changeover latch for «long / short» preignition time
UL3	Changeover latch for «with / without» repetition
W	Limit thermostat or pressure switch
Z	Ignition transformer

Dimensions

Dimensions in mm

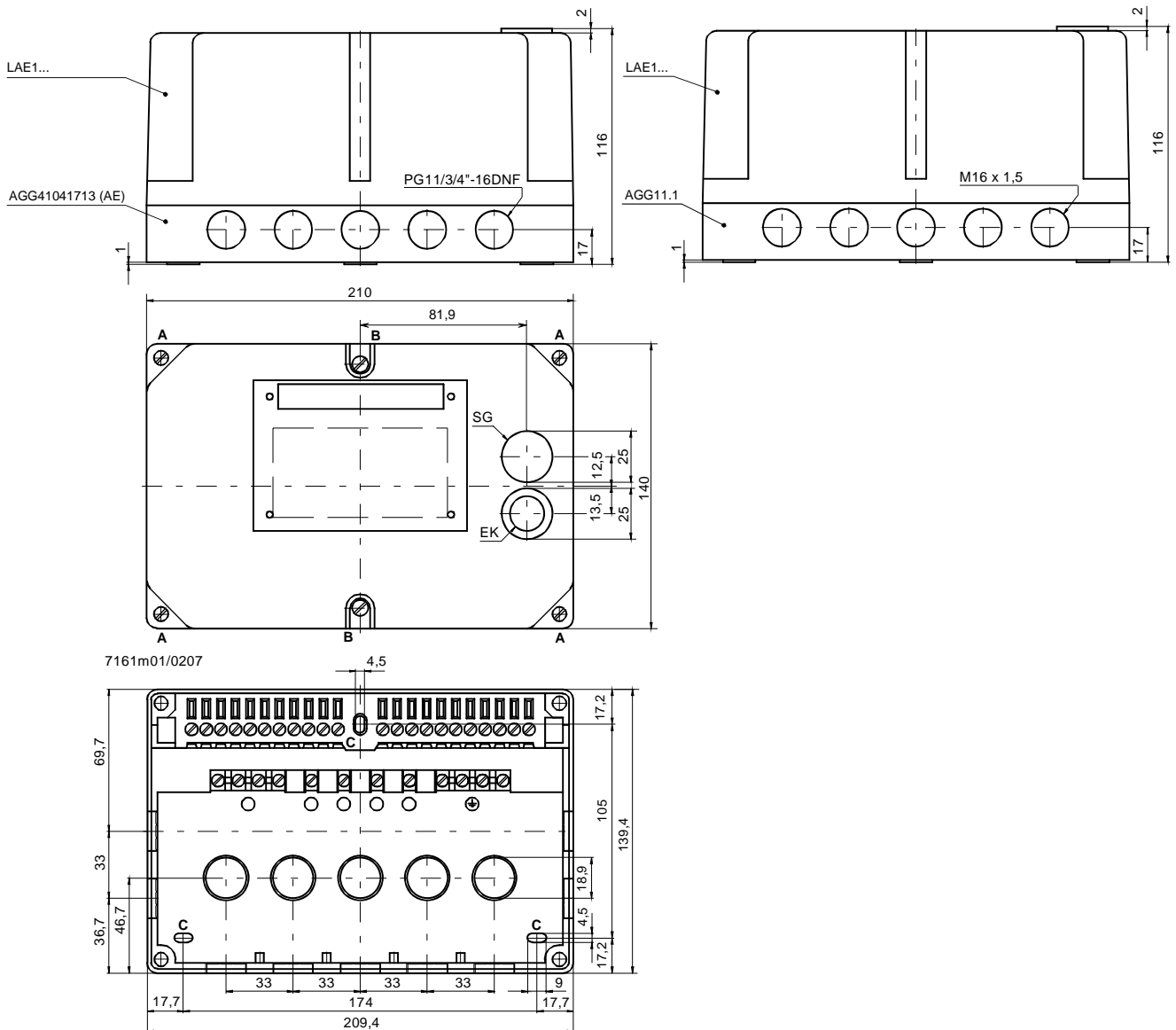

To remove the LAE1... from its plug-in base, it is **merely** necessary to loosen the 4 screws «**A**».

To remove the unit cover, also loosen the 2 screws «**B**».

Legend

- C** Elongated holes for fixing the plug-in base
- SG** Viewing window
- EK** Lockout reset button