



## Burner Controls

## LFE1...

---

The LFE1... burner control is designed for use with forced draft gas and dual-fuel burners of any capacity, in intermittent operation.

The LFE1... and this Data Sheet are intended for use by OEMs which integrate the burner controls in their products.

### Use

---

The LFE1... is designed for the fully automatic control and supervision of single-stage, multi-stage or modulating gas or dual-fuel burners. It is suited for use with expanding flame and interrupted pilot type gas burners.

Flame supervision is ensured by means of an ionization probe or a QRA... UV flame detector.

Ignition spark proving with a UV flame detector is also possible.

When used in connection with a gas valve proving system LDU11... (refer to Data Sheet N7696), the control sequence of the LFE1... can be extended to include automatic gas valve proving.

All types of burner controls comply with the relevant European standards for gas and oil burners of any capacity.

The LFE1... can control the following burner plant components:  
fan motor, flue gas fan, air damper, ignition transformer, 1 to 3 fuel valves, load controller and an external lockout warning device.

## Use (cont'd)

---

### Special features

- Prepurge time adjustable between 8 and 63 seconds
- Operation optional with or without postpurging
- Fully automatic control of the air damper, irrespective of the actuator running time
- The air pressure check can be combined with the functional check of the air pressure switch prior to startup
- Ignition optional: direct ignition, with pilot burner, without or with ignition spark proving
- First and second safety time adjustable between 0 and 9 seconds
- Automatic test of the UV flame detector during burner off periods and during the purging times
- Optional semi-automatic start and operation
- Built-in lockout warning lamp

## Warning notes

---



**To avoid injury to persons, damage to property or the environment, the following warning notes should be observed!**

**The unit may only be opened, interfered with or modified by qualified staff!**

- All activities (mounting, installation and service work, etc.) must be performed by qualified staff
- Before performing any wiring changes in the connection area of the LFE1..., completely isolate the burner control from the mains supply (all-polar disconnection)
- Ensure protection against electric shock hazard by providing adequate protection for the terminals
- Each time work has been carried out (mounting, installation, service work, etc.), check to ensure that wiring is in an orderly state and make the safety checks as described in «Commissioning notes»
- Press the lockout reset button / operation button extension only manually (applying a force of no more than 10 N) without using any tools or pointed objects
- **Do not press the lockout reset button on the unit or the remote lockout reset button for more than 10 seconds since this damages the lockout relay in the unit**
- Fall or shock can adversely affect the safety functions. Such units must not be put into operation, even if they do not exhibit any damage
- Sealing screws may only be loosened and factory settings may only be changed by authorized staff

## Mounting notes

---

- Ensure that the relevant national safety regulations are complied with

## Installation notes

---

- Observe the polarity  
Burner controls LFE1... are able to detect wrong polarity of live and neutral conductors, in which case they initiate lockout at the end of «TSA»

## Electrical connection of flame detectors

---

It is important to achieve practically disturbance- and loss-free signal transmission:

- Never run the detector cable together with other cables
  - Line capacitance reduces the magnitude of the flame signal
  - Use a separate cable
- Observe the permissible length of the detector cables (refer to «Technical data»)
- Insulation resistance
  - Must be a minimum of 50 MΩ between ionization probe and ground
  - Soiled detector holders reduce the insulation resistance, thus supporting creepage currents
- Earth the burner in compliance with the relevant regulations; earthing the boiler alone does not suffice
- The ionization probe does not offer protection against electric shock hazard
- Locate the ignition electrode and the ionization probe such that the ignition spark cannot arc over to the ionization probe (risk of electrical overloads)
- Always run the high ignition cables separately while observing the greatest possible distance to the unit and to other cables

## Commissioning notes

---

- The program indicator shows continuously the program sequence in the eyehole of the cover
- The motor of the sequence switch can be switched off (to simplify burner adjustments)
- The camshaft of the sequence switch can be turned manually
- Optional electrical remote lockout reset
- For setting notes, refer to «Setting facilities on the burner control»
- When commissioning the plant for the first time or when doing maintenance work, make the following safety checks:

	<b>Safety check to be carried out:</b>	<b>Anticipated response:</b>
a)	Burner startup with flame detector darkened	Lockout at the end of «TSA»
b)	Burner startup with flame detector exposed to extraneous light	Delayed lockout
c)	Burner operation with simulated loss of flame; for that purpose, darken the flame detector during operation and maintain that status	Lockout
d)	Burner startup without air pressure signal	Lockout during the prepurge time
e)	Burner operation with simulated air pressure failure	Immediate lockout

## Standards and certificates



- Conformity to EEC directives
- Electromagnetic compatibility EMC (immunity)
  - Directive for gas-fired appliances
  - Low-voltage directive

89 / 336 / EEC  
90 / 396 / EEC  
73 / 23 / EEC



ISO 9001: 2000  
Cert. 00739



ISO 14001: 2004  
Cert. 38233

Identification code to EN 298

F B L L B N

Type				
LFE1.1 / 8854	x	x	---	x
LFE1 / 8851	x	x	x	x
LFE1 / 8853	x	x	x	x
LFE1 / 8866	x	x	x	x
LFE1 / 8867	x	x	x	x
LFE1 / 8868	x	x	x	x
LFE1 / 8892	x	x	x	x

## Disposal notes



The unit contains electrical and electronic components and must not be disposed of together with household garbage.  
Local and currently valid legislation must be observed.

## Mechanical design

LFE1...

- Plug-in design
- The built-in unit fuse protects the control contacts of burner control against overloads
- Able for optional mounting position at burner, on control panes or in control cabinets
- Control unit driven by synchronous motor, the auxiliary relays, the electronic flame signal amplifier as soon as all the rest of switch, control and adjustable elements are build-on at stable PCBs and included in test circuit of burner control
- The burner control is secured to its base with 4 screws. The unit cover is protected against tampering by means of 2 sealing screws (refer to «Dimensions»)

Housing

- Large connection area
- Made of black, impact-proof and heat-resistant plastic
- Lockout reset button with viewing window, located behind it are
  - the lockout warning lamp
  - the lockout indicator
    - coupled to the program shaft
    - visible in the transparent lockout reset button
    - uses easy-to-remember symbols to indicate the type of fault and the point in time lockout occurred
- 4 extra terminals for the earth conductor, 4 extra terminals for the neutral conductor, and 4 auxiliary terminals

## Type summary

Type reference *	Mains voltage	Factory settings for mains frequency	t1	TSA	t9
			LFE1.1 / 8854	AC 220...240 V	50 Hz
LFE1 / 8851	60 s				
LFE1 / 8853	30 s				
LFE1 / 8866	AC 100...110 V	60 Hz			
LFE1 / 8867					
LFE1 / 8868	AC 220...240 V	50 Hz	60 s	5 s	5 s
LFE1 / 8892					

\* The marking is given inside housing in the range of the contacts

## Ordering

**Burner control**, without plug-in base refer to «Type summary»  
 Plug-in base not included in delivery, must be ordered as a separate item!

**Plug-in base** ordered as a separate item

- Plug-in base **AGG41041713 (FE)** with Pg11 thread for cable entry glands
- Plug-in base **AGG13.1** with M16 thread for cable entry glands

### Flame detectors

- Ionization probe supplied by thirds
- UV detectors QRA... refer to Data Sheet N7712

## Technical data

General unit data LFE1...	Mains frequency	AC 220 V -15 %...AC 240 V +10 % AC 100 V -15 %...AC 110 V +10 %
	Mains frequency	50...60 Hz $\pm 6$ %
	Unit fuse (built-in)	T6.3H250V to DIN EN 60127
	Primary fuse (external)	max. 16 A (slow)
	Weight	approx. 2 kg
	Power consumption	
	- in startup	9 VA
	- in operation	6 VA
	Mounting position	optional
	Degree of protection	IP40, when built in, with the exception of the connection area (terminal base)
	Safety class	II
	Perm. loading of control outputs	
	- Per terminal	max. 4 A
	- Total	max. 5 A
	Environmental conditions	<b>Storage</b>
Climatic conditions		class 1K3
Mechanical conditions		class 1M2
Temperature range		-20...+60 °C
Humidity		< 95 % r.F.
<b>Transport</b>		DIN EN 60721-3-2
Climatic conditions		class 2K2
Mechanical conditions		class 2M2
Temperature range		-50...+60 °C
Humidity		< 95 % r.h.
<b>Operation</b>		DIN EN 60721-3-3
Climatic conditions		class 3K5
Mechanical conditions		class 3M2
Temperature range		-20...+60 °C
Humidity		< 95 % r.h.



**Condensation, formation of ice and ingress of water are not permitted!**

Flame supervision

	Ionization probe	QRA...
Required detector current		
- At AC 100 V and AC 220 V	Min. 8 $\mu$ A	Min. 150 $\mu$ A
- At AC 110 V and AC 240 V	Min. 9 $\mu$ A	Min. 200 $\mu$ A
Possible detector current	Max. 100 $\mu$ A	Max. 650 $\mu$ A

Flame detector

Perm. length of connection cable	20 m <sup>1)</sup>	20 m <sup>1)</sup>
Perm. ambient temperature	---	60 °C
Type of insulation	---	Protective insulation

1) If longer distances need to be covered, use low capacitance cable (e.g. single-core cable, totally max. 2 nF)

## Function

---

### Prerequisites for burner startup

The burner can be started only when:

- the burner control's sequence switch is in its start position
- the burner control has not locked out, e.g. caused by a defective UV tube
- the contacts of all control and safety devices in the control loop between terminals 8 and 9 are closed
- the air pressure switch does not indicate air pressure

Defects in the flame supervision circuit or in the burner control itself prevent startup or lead to lockout during the startup sequence.



If the air damper is not controlled by the burner control, terminals 20, 21 and 22 must be interconnected.

### Program sequence on startup

First, the fan motor is activated via terminal 3, and the actuator is controlled via terminal 22.

As soon as the air damper reaches its fully open position, the burner control's sequence switch starts running and the prepurge time commences.

The minimum air pressure set on the air pressure switch must be reached within 10 seconds (5 seconds with the LFE1.1) (or 7 seconds [3.5 seconds with the LFE1.1] with postpurging) and must be maintained until controlled shutdown occurs. Otherwise, the burner control will initiate lockout.

A flame signal during the prepurge time also leads to lockout.

On completion of the set prepurge time, the damper receives the control command to return to the fully closed position.

The sequence switch remains stationary during the time the air damper travels to its closed position.

As soon as the signal contact for minimum air is operated by the actuator, the sequence switch starts running again and continues with the burner's program sequence, which can no longer be influenced from externally:

- Preignition (3 seconds / 1.5 seconds with the LFE1.1)
- Release of the first fuel valve at terminal 5 (the fuel valve of a pilot burner, which must be shut on completion of the second safety time, must be connected to terminal 10)
- Completion of the set safety time. If no flame is established during that period of time, lockout will occur (always with interlocking of the burner control)
- Following an interval of 11 seconds (5.5 seconds with the LFE1.1) of the first fuel valve, the second fuel valve will be released
- The pilot burner, if connected to terminal 10, will be shut
- The load controller will be switched on following a further interval of 12 seconds (6 seconds with the LFE1.1). The burner's operating position has thus been reached. From now on, the load controller controls the burner's output by increasing or decreasing the fuel throughput and the air flow in response to the heat demand (ratio control). This can be accomplished either in a stepwise fashion, e.g. with a thermostat, or continuously by means of a modulating controller

Loss of flame during operation always leads to lockout.

### Startup with ignition spark supervision

In principle, the program sequence is the same as startup without ignition spark supervision.

Exceptions:

- If the UV flame detector does not receive an input signal during the preignition time, lockout will occur before any gas is released, that is, safety time TSA = 0 seconds
- With ignition spark supervision, the safety time for the pilot burner can only be adjusted between 0...6 seconds (= TSA' in the sequence diagram of the sequence switch)

**Function (cont'd)**

Control sequence following a controlled shutdown

Controlled shutdown takes place as soon as one of the control or monitoring devices in the control loop between terminals 8 and 9 opens its contacts. As a result, the fuel valves are immediately shut and the sequence switch is restarted to program postpurging, if scheduled. On completion of the postpurge time, the sequence switch has reached its start position again, which is maintained until the next switch-on command is given. During the postpurge time, flame supervision is started again. Hence, any flame signal that occurs during that period of time will lead to lockout.

Control sequence following lockout reset of the burner control

After pressing the built-in or remote lockout reset button, the sequence switch will return to its start position. In that case, the only burner plant component that is switched on is the fan motor connected to terminal 17. Since in normal circumstances the control thermostat or pressurestat continues to call for heat, the burner control immediately triggers a new start when the start position is reached.

**Program indicator**

The program indicator continuously indicates the progress of the startup sequence. The letters on the indicator disk correspond to those in the adjacent sequence switch diagram. The numbers give the remaining prepurge time. In the event of lockout, both sequence switch and program indicator stop, showing the phase of operation during which lockout occurred.

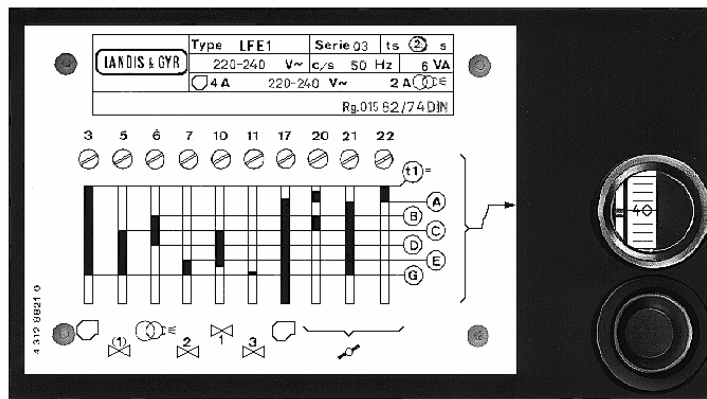

Reading the program indicator

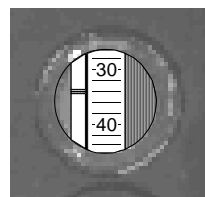

← Prepurge time lasts another 35 seconds

Valve 2 at terminal 7 opens →

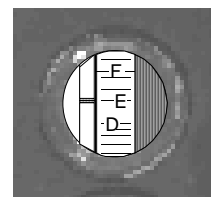



# Basic diagram

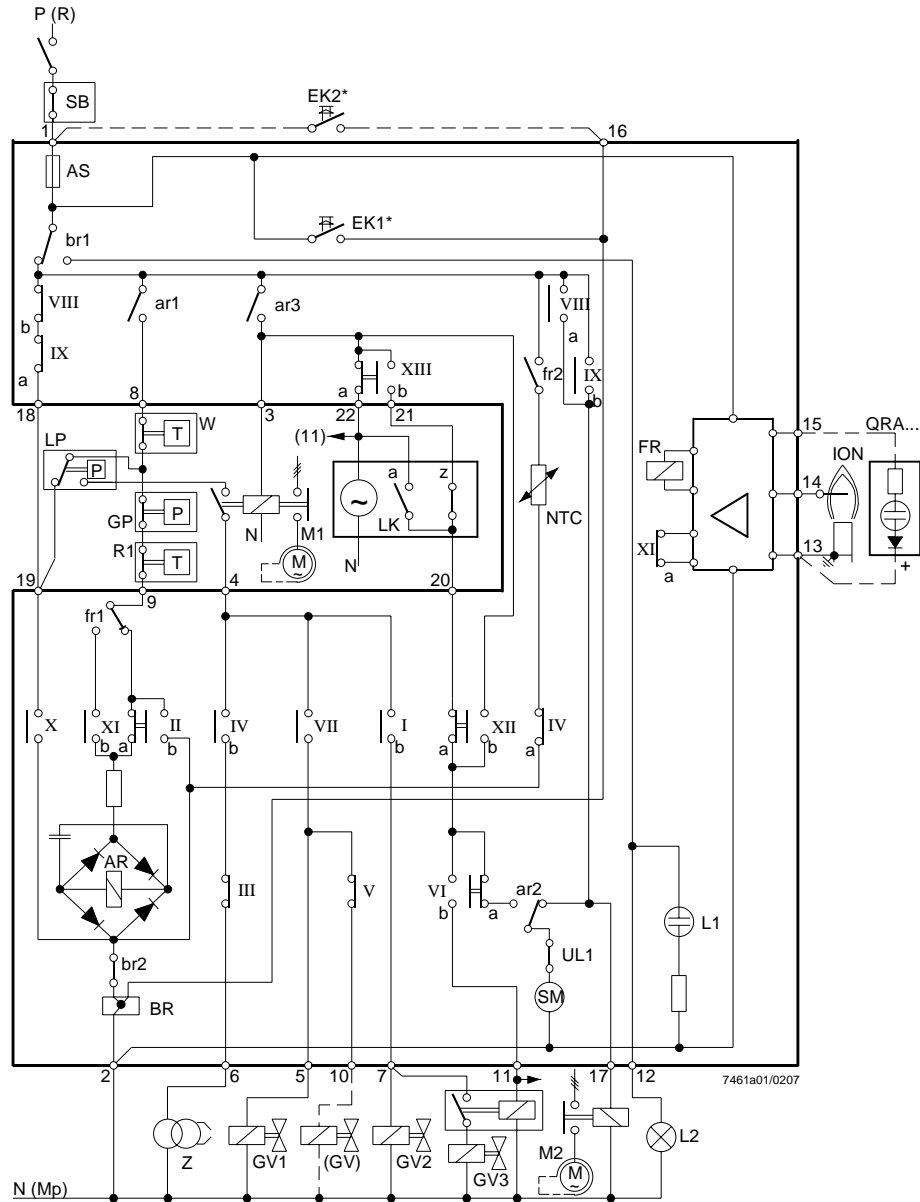

When using UV flame detector QRA..., terminal 13 must be earthed.

## Legend

AR	Load relay with contacts «ar...»	LF	UV flame detector QRA...
AS	Unit fuse	LP	Air pressure switch
BR	Lockout relay with contacts «br...»	L1	Lockout warning lamp (built-in)
BS...	Operating switch	L2	Lockout warning lamp (external)
c	Fan contactor with contacts «c...»	M...	Fan
d	Auxiliary relay with contacts «d...»	NTC	Delay element (negative temperature coefficient)
e	Thermal overload contact	OV...	Oil valve
EK1	Lockout reset button on the burner control	QRA...	UV flame detector
EK2	Remote lockout reset button	R, R1	Control thermostat or pressurestat
ION	Ionization probe	R2	Load controller
FR	Flame relay with contacts «fr...»	RV	Control valve
FW	Flame supervision	SB	Safety limiter
GP	Gas pressure switch	SM	Synchronous motor of the sequence switch
GV...	Gas valve	SQ...	Air damper actuator (type reference)
(GV)	Gas valve for a pilot burner that is switched off after the second safety time	UL1	Operating switch of the sequence switch motor (can only be accessed when housing cover is removed)
H	Main switch	W	Temperature or pressure limiter
LK	Actuator with end or auxiliary switches a = actuator travels to the fully open position (maximum amount of air) z = actuator travels to the fully closed position (min. amount of air)	Z	Ignition transformer
		*	Do not press lockout reset button «EK...» for more than 10 seconds!

## Sequence diagram of sequence switch

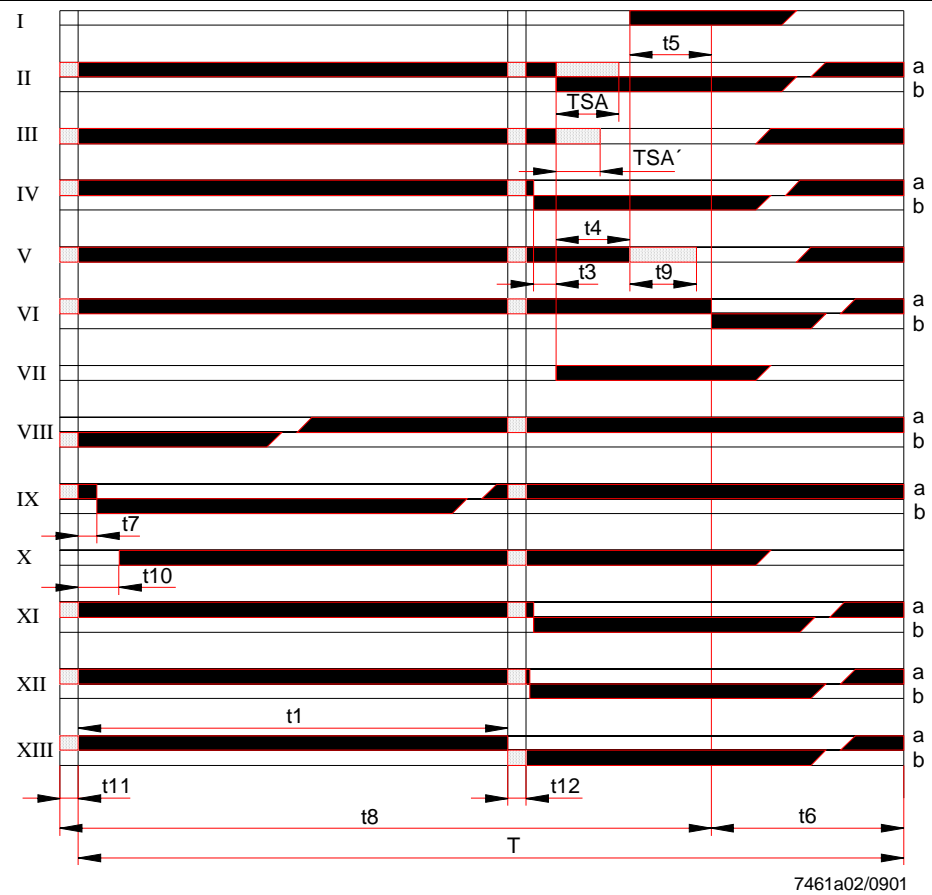

Switching times (Factory settings: refer to «Type summary» and «ordering»)

	LFE1...	LFE1.1...	
T	120 s	60 s	Running time of sequence switch
t1	8...63 s	4...31.5 s	Prepurge time (adjustable)
TSA	0...9 s	0...4.5 s	First safety time (adjustable, setting 0 s for ignition spark supervision)
TSA'	0...6 s	0...3 s	Safety time for the pilot burner on startup with ignition spark supervision
t3	3 s	1.5 s	Preignition time (safety time for ignition spark supervision)
t4	11 s	5.5 s	Interval between release of the first and second fuel valve
t5	12 s	6 s	Interval between release of the second and third fuel valve or load controller
t6	$T - (30 + t1)$	$T - (15 + t1)$	Postpurge time
t7	3 s	1.5 s	Delay time
t8	$t1 + 30 + t11 + t12$	$t1 + 15 + t11 + t12$	Duration of startup sequence
t9	0...9 s	4.5 s	Second safety time with interrupted pilot burners
t10	10 s	5 s	Preset time for air pressure check
t11	optional	optional	Opening time of actuator «SA»
t12	optional	optional	Closing time of actuator «SA»
Maximum permissible afterburn time (from the beginning of «t6»)			
	7 s	3.5 s	

## Setting facilities on the burner control

### General notes

- Prior to making any settings, disconnect the burner control from the mains supply
- Loosen all 6 retaining screws and remove the unit cover
- The switching cam numbering starts from the motor
- The camshaft can be manually turned to any position (direction of rotation clockwise when viewed from the sequence switch motor)

### Setting elements

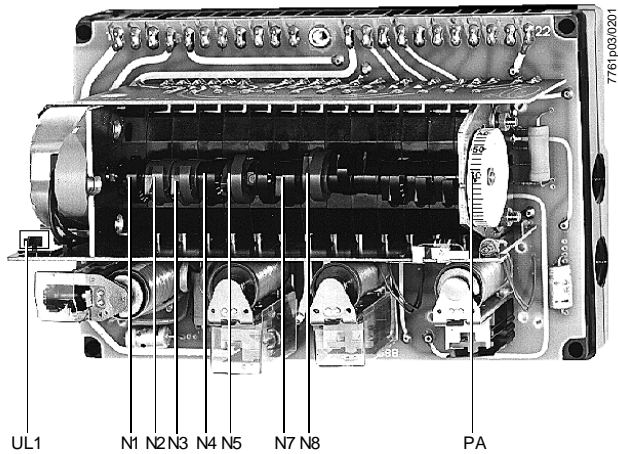

- UL1 Operating switch ON / OFF of the sequence switch motor
- N1 Cam 1, fixed
- N2, N3 Cams 2 and 3, adjustable (first safety time)
- N4 Cam 4, fixed
- N5 Cam 5, adjustable (second safety time)
- N7 Cam 7, fixed
- N8 Cam 8, adjustable (prepurge time)
- PA Program indicator disk

### Setting the prepurge time

- Loosen the securing screw of the red cam N8
- Turn camshaft manually until the required prepurge time appears next to the index mark (stamped on the sequence switch bracket)
- Hold camshaft firmly and rotate cam N8 until the contact stud actuated by it jumps out or until the cam runs against the stud
- Tighten the cam securing screw carefully and then check the adjusted time for accuracy. The adjustable time is also visible through the viewing window when the burner control is in its start position

Adjustment of the setting mark of the red cam N8 to the time marks on the black cam N7 produce the prepurge times shown below table.

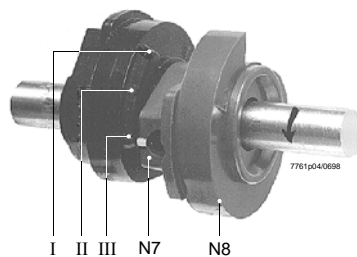

Cam N8 adjusted to...

LFE1...	Cam N8 adjusted to...			LFE1.1...
... cam N7	mark	I	t1 = 8 s	4 s
		II	18 s	9 s
		III	28 s	14 s
<b>Setting at the stop</b>			63 s	31.5 s
<b>Factory setting</b>			approx. 30 s or 60 s	approx. 15s or 30 s

## Setting facilities on the burner control (cont'd)

### Setting the safety times

The settings are made by means of the red cams of the sequence switch. Their time marks serve as adjustment guides. On completion of the settings, the securing screws of the cams should be tightened carefully to prevent inadvertent readjustments.

### First safety time TSA

(Operation without ignition spark supervision)

- Loosen the securing screws of cams N2 and N3
- Hold cam N1 and rotate cam N2 so that its setting mark aligns with the relevant time mark of cam N1 (see illustration and table; intermediate settings are possible). Secure cam N2
- Rotate cam N3 so that its setting mark is against the lower stop of cam N2. Secure cam N3
- Check the adjusted safety time. The new safety time is to be indicated on the plate (setting slot accessible from the bottom of the unit cover)

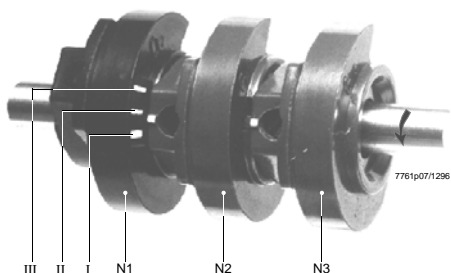

Cam N2 adjusted to...

LFE1...	Cam N2 adjusted to...	LFE1.1...
... cam N1, time mark I	TSA = 0 s	0 s
	II	4.5 s
	III	9 s
Factory setting	Depending on variant	< 2 s

### First safety time TSA'

(Operation with ignition spark supervision)

- Loosen the securing screws of N2 and N3
- Hold cam N1 firmly, set the setting mark of cam N2 to the time mark I of cam N1 and secure cam N2
- Hold cam N2 firmly, set the setting mark of cam N3 to the desired time and secure cam N3 (see illustration and table)
- Check the adjusted safety time

Cam N3 adjusted to...

LFE1...	Cam N3 adjusted to...	LFE1.1...
... the stop in the direction of the arrow	TSA = 0 s	0 s
... the stop in the other direction	6 s	3 s
Factory setting	Depending on variant	< 2 s

### Second safety time t9

- Loosen the securing screw of cam N5 and set its setting mark to the relevant time mark of cam N4 (see illustration and table; intermediate settings can be made)

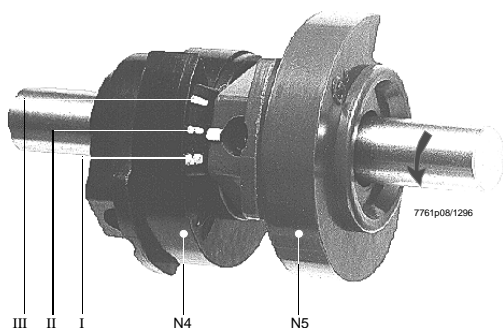

Cam N5 adjusted to...

LFE1...	Cam N5 adjusted to...	LFE1.1...
... cam N4, Time mark I	t9 = 0 s	0 s
	II	4.5 s
	III	9 s
Factory setting	Depending on variant	< 2 s

## Connection examples and sequence diagrams

Connection examples  
for expanding flame  
burners

Actuator control by the LFE1...

No load control.

When using UV flame detector QRA..., terminal 13 must be connected to earth.

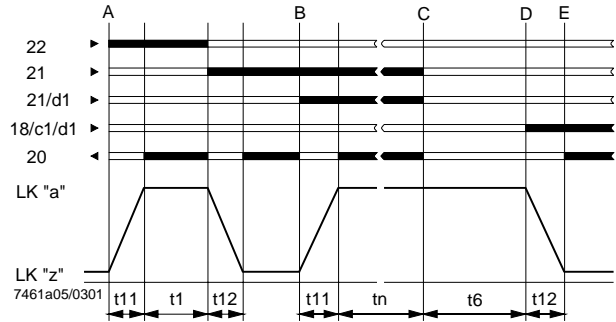
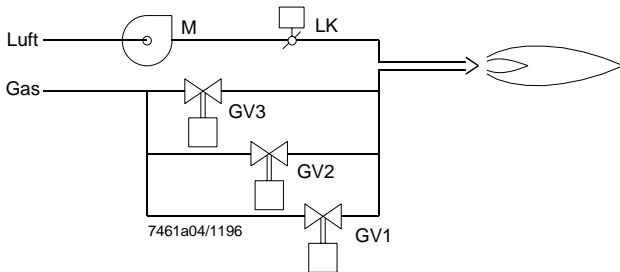
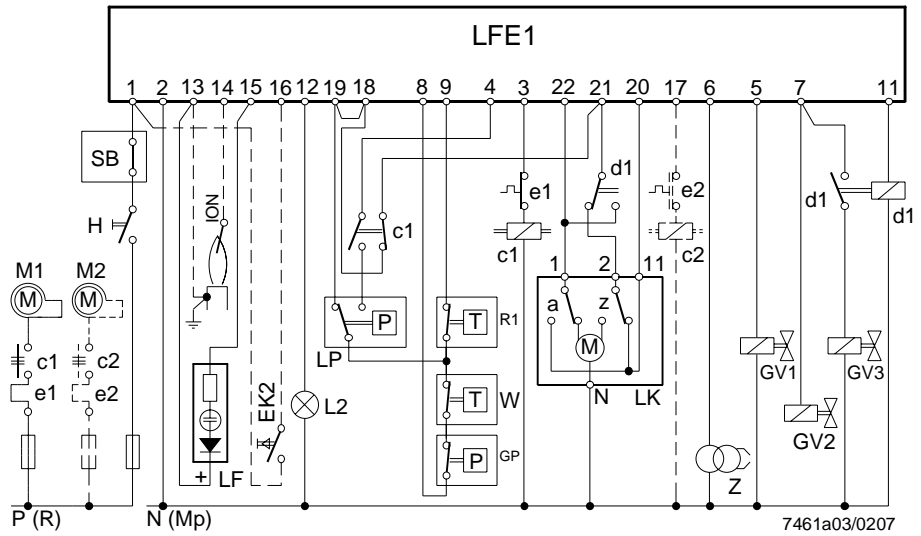

Air damper control (detailed)



In the case of burners with no air damper or with an air damper not controlled by the burner control, terminals 20, 21 and 22 must be interconnected and circuit path 18-c1-21 becomes obsolete.

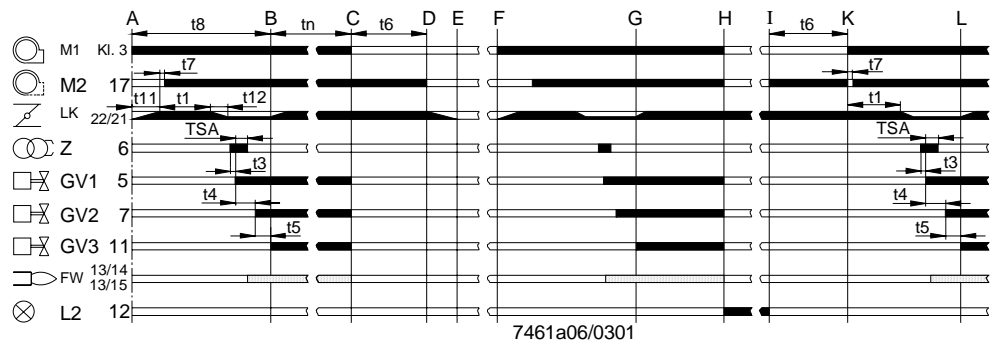

## Connection examples for interrupted pilot burners

On / off control with checked air damper operation.

When using UV flame detector QRA..., terminal 13 must be connected to earth.

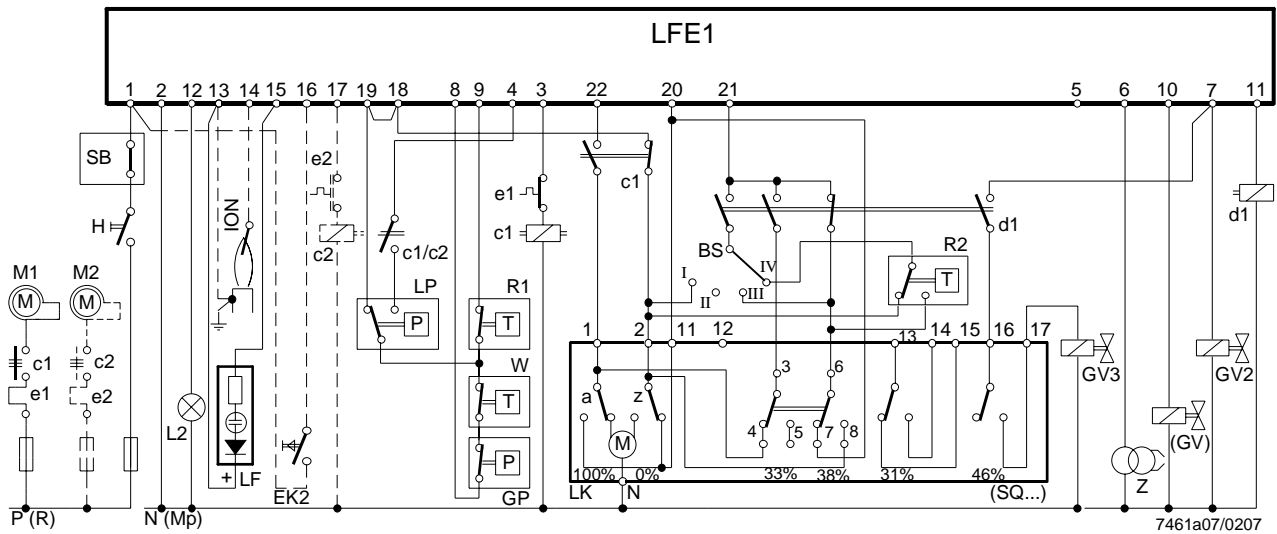

### Operating switch BS

- I Nominal load
- II Stop
- III Part load
- IV Automatic control

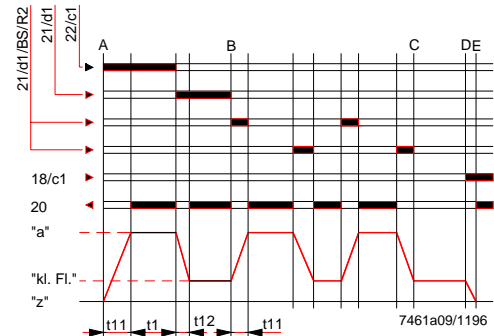
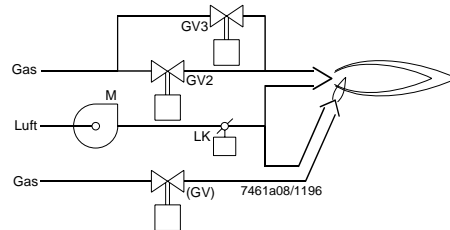

### Air damper control (detailed)

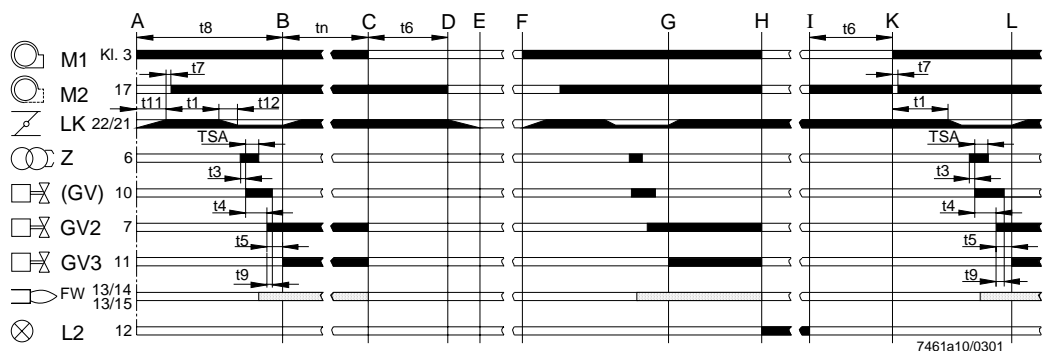

### Legend to the sequence diagram

- |     |                       |     |                       |
|-----|-----------------------|-----|-----------------------|
| A   | Start                 | G-H | Operation             |
| A-B | Normal start          | H   | Loss of flame         |
| B-C | Operation             | H-I | Fault                 |
| C   | Controlled shutdown   | I   | Reset                 |
| C-D | Postpurgung           | I-K | Run in start position |
| D-E | Air damper closing    | K   | Re-start              |
| E-F | Burner off time       | K-L | Startup sequence      |
| F   | Re-start              | L   | Operation             |
| F-G | Run in start position |     |                       |

## Connection examples for interrupted pilot burners (cont'd)

LFE... for firing on gas  
or oil, optional

UV flame detectors can supervise both oil and gas flames, but gas flames can also be supervised with ionization probes.

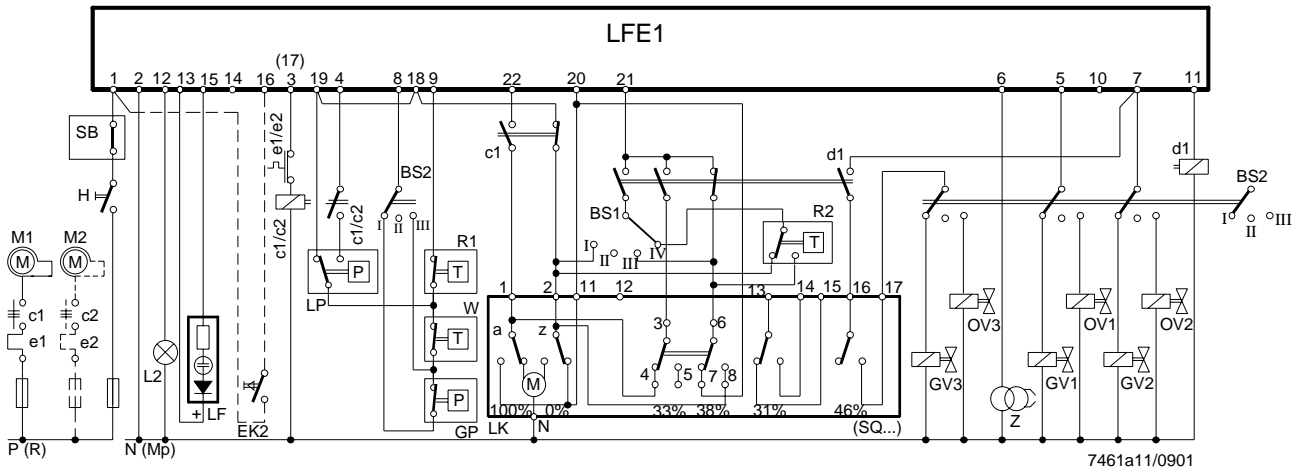

When using UV flame detector QRA..., terminal 13 must be connected to earth.

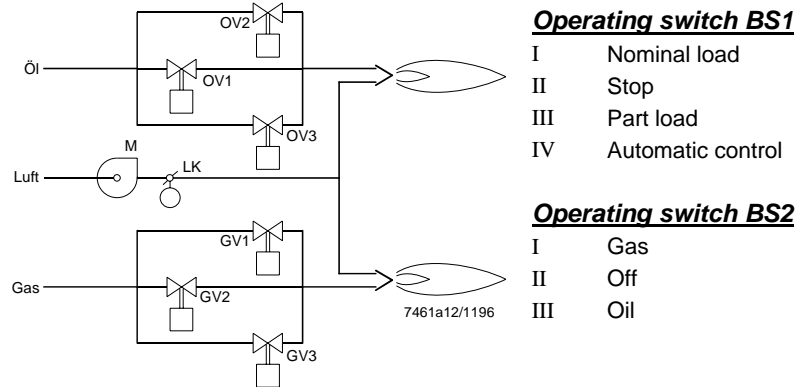

## Connection examples for modulating burner control including checked air damper control

Modulating burners designed for the continuous adjustment of the burner's output require a temperature or pressure control system, in addition to the standard burner control equipment, for example:

Modulating controller	RWF40...
Temperature or pressure sensor with integrated setpoint adjuster	Q...
Actuator for control of the air damper and the fuel throughput (ratio control)	SQ...
Auxiliary relay	d1
Operating switch	BS
Control valve or similar for adjustment of the amount of fuel	RV

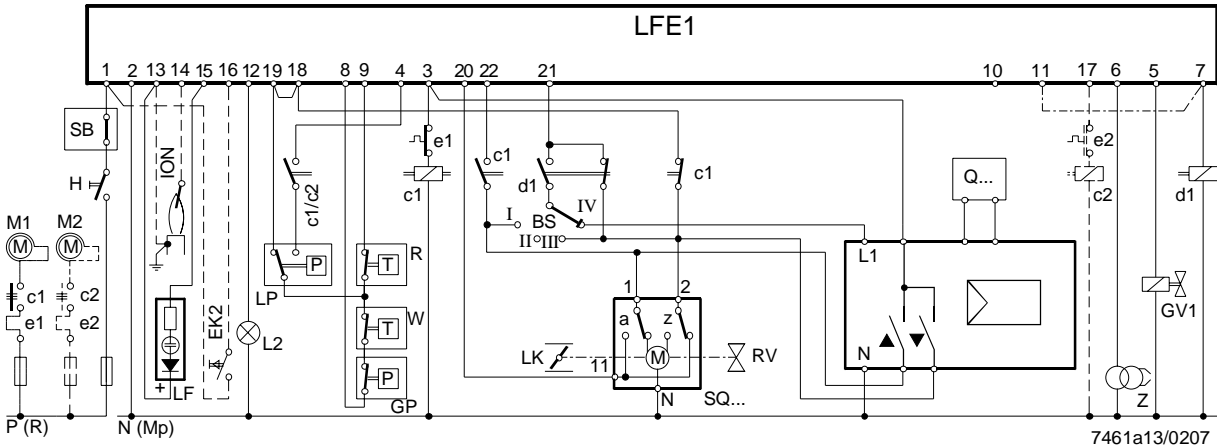

When using UV flame detector QRA..., terminal 13 must be connected to earth.

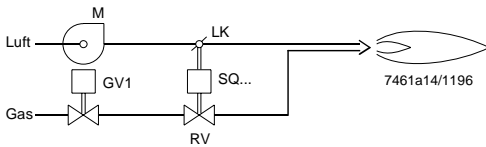

### Operating switch BS

- I Nominal load
- II Stop
- III Part load
- IV Automatic control

### Air pressure switch «LP»

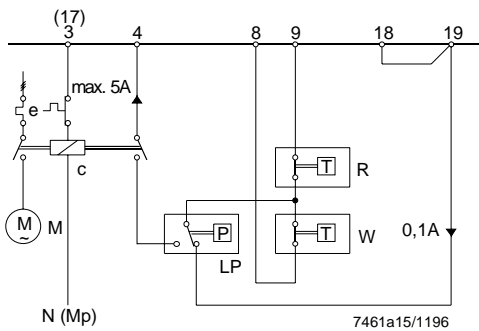

The air pressure is constantly monitored from burner start to controlled shutdown. If the set minimum air pressure is not reached 10 seconds \* after the start of prepurging (7 seconds \*\* with the program with pre- and postpurging), or the air pressure is lost again any time thereafter, the burner control will initiate lockout. If the air pressure switch «LP» is connected as shown in the adjacent diagram, the switch is also automatically tested for correct functioning prior to each start. If the contact's position is not correct, startup will be prevented.

\* (5 seconds with the LFE1.1...)

\*\* (3.5 seconds with the LFE1.1...)

### Measuring circuit for ionization current

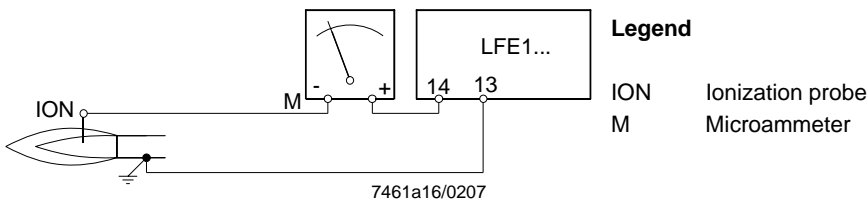

#### Legend

- ION Ionization probe
- M Microammeter

**⚠** Ignition can have an impact on the ionization current.  
(Possible remedy: interchange the ignition transformer's primary connections)



# Dimensions

Dimensions in mm

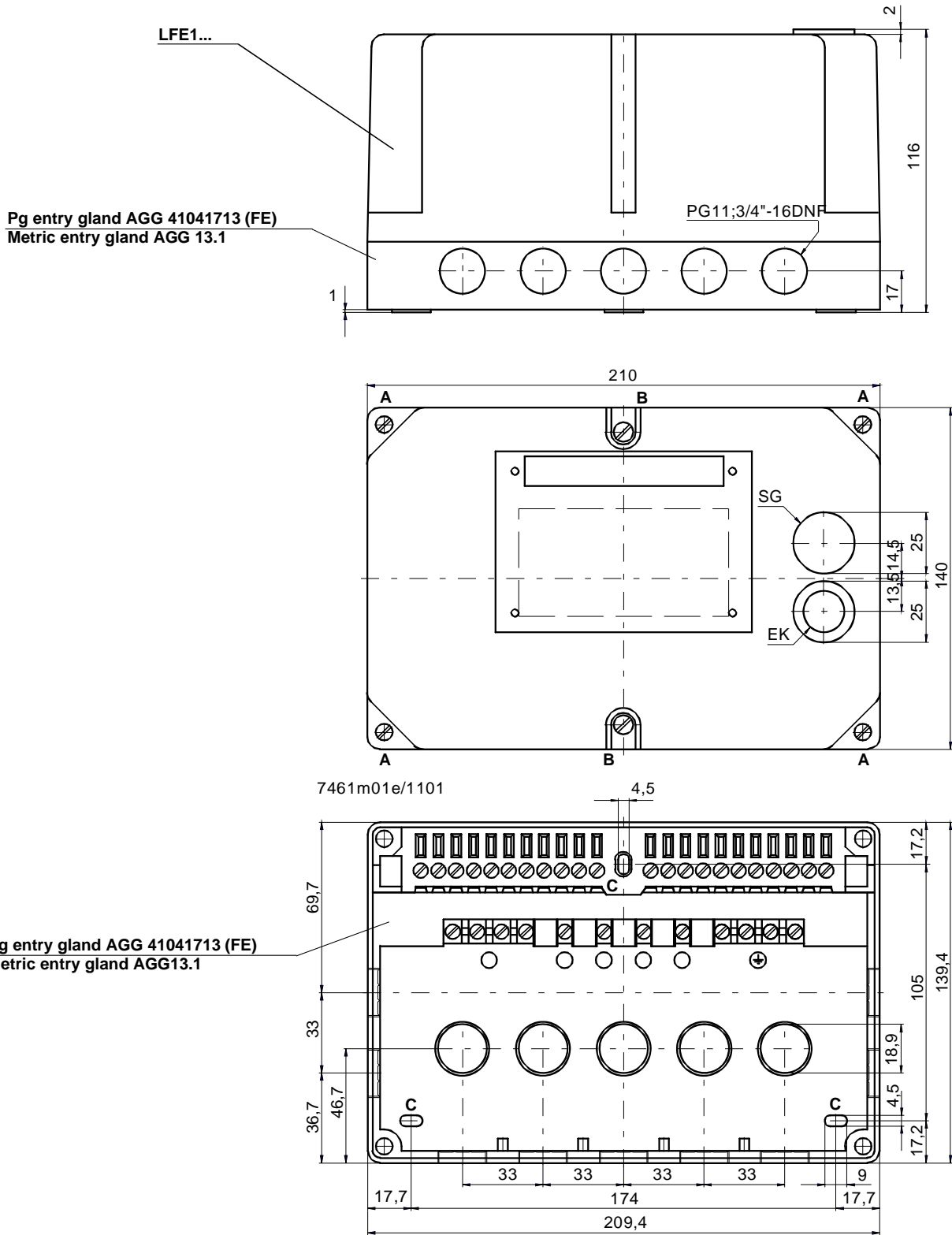

To remove the burner control from its plug-in base, loosen the 4 screws **A**.  
 To remove the unit cover, loosen the 2 screws **B** also.  
**C**: elongated holes for securing the base  
**EK**: lockout reset button  
**SG**: viewing window